



SELF-PRIMING CENTRIFUGAL PUMPS

UKM-S SERIES



TECHNICAL MANUAL



MAS DAF MAKİNA SANAYİ A.Ş.

Head Office: Atasehir Bulvarı ATA Çarşısı.K4.No:59
Tel: +90 (216) 456 12 00 (Pbx)- Fax:+90 (216) 456 25 00

İSTANBUL – TÜRKİYE
E-Mail: masgrup@masgrup.com
Web : www.masgrup.com

UKM-S Self-Priming Centrifugal Pump

General Specifications



Fields of Application

- Pumping of domestic and industrial sewage.
- Pumping of chemical and industrial waste water.
- All kinds of drainage and dewatering works.
- Pumping of polluted liquids of industrial processes.

Pumped Liquids

UKM-S series pumps are designed for handling mild industrial corrosives, mud or slurries containing large entrained solids.

Design

- UKM-S series pumps are self-priming centrifugal pumps model with a suction check valve.
- Since they are self-priming they can be mounted high and dry above the sump a floor level with only suction line in the liquid.
- Pumps are available as basic units for connection to diesel engines as well as the electric motors via flexible couplings.
- UKM-S series are available in six basic discharge sizes: 2", 3", 4", 6", 8", 10".
- Impellers are open type with two vane and handle solids up to 76 mm (3") depending on the pump type.
- Unclogging is very quick and simple. Removable coverplate permits easy access to impeller, wear plate and seal. The clog is removed and pump returned to normal operation in minutes without disturbing suction or discharge piping.
- Volute casing is designed to provide large volume of liquid retention for dependable priming and repriming performance. No external or internal priming devices are used.
- Suction check valve (Flap Valve) is one piece molded and specially designed. It can be removed or installed without disturbing suction piping.
- Bearing housing is supported by volute housing. It eliminates alignment problem.
- UKM-S series pumps are designed to reprime automatically in a completely open system. They can do it with the pump casing only partially filled with liquid and with a completely dry suction line.

Pump Shaft

Chromium steel (AISI 420) fine grained shafts are used on UKM-S pumps.

Bearings

Single Row Ball Bearings and Double Row Angular Contact Ball Bearings are used in sizes to withstand thrust and radial stresses. Oil bath lubrication system is used for bearings.

Shaft Seal

For the shaft seal, the mechanical seal is used.

Technical Data

- Suction Flanges : 2" – 10"
- Discharge Flanges : 2" – 10"
- Speed Range : 650-2900 rpm
- Capacity Range : 50–730 m³ / h
- Head Range : 4–40 mwc

Drive

Common electric motors according to IEC (and NEMA) and combustion engines can be used to drive the pump.

Identification Code for Pump

Example:

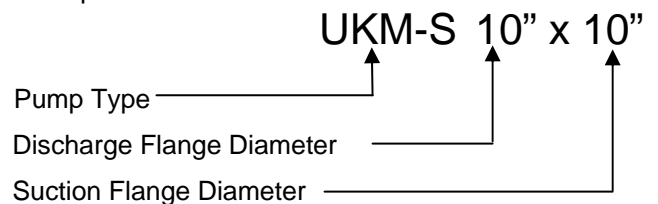

UKM-S Self-Priming Centrifugal Pump

Sectional Drawing and Part List (2x2, 3x3, 4x4, 6x6, 8x8)

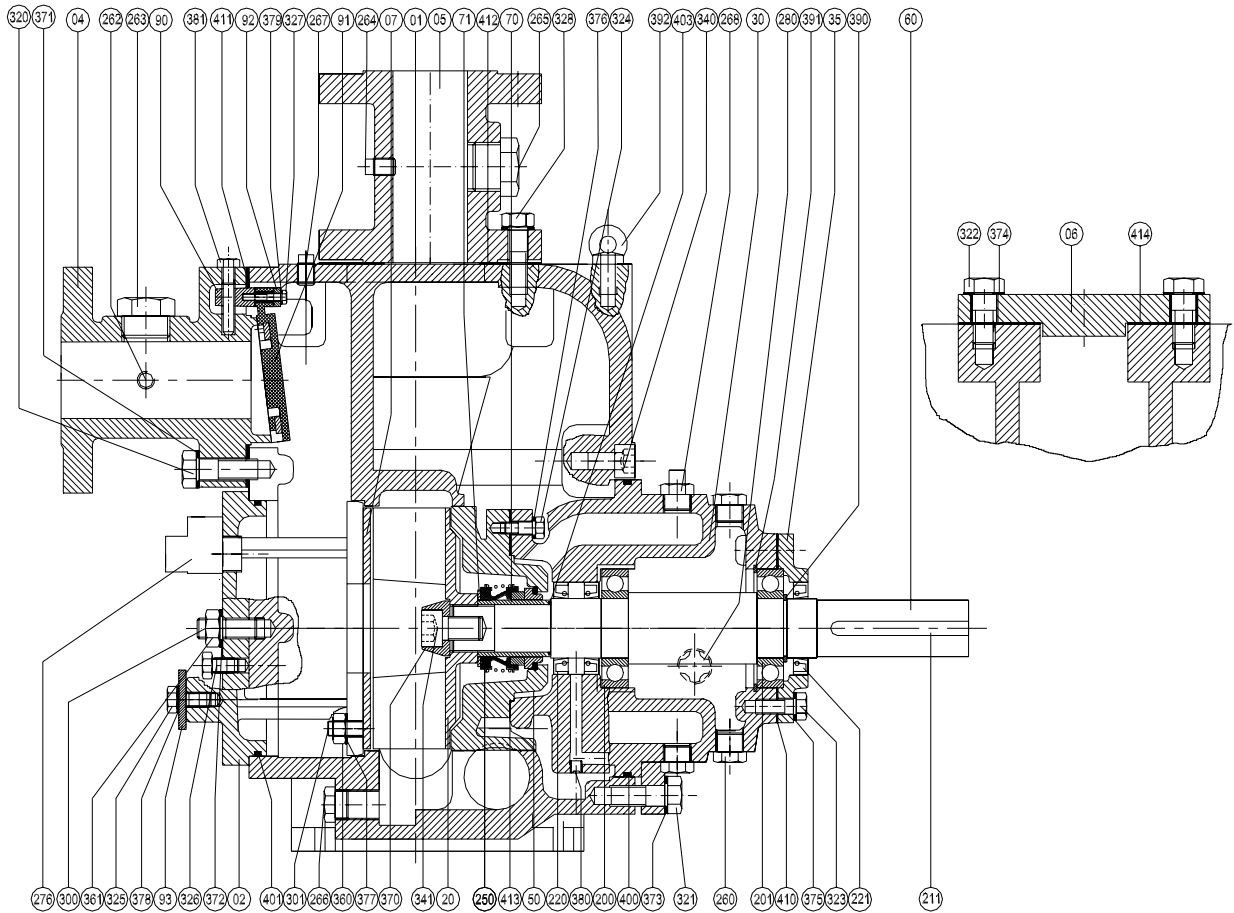

Parts List

Part No	Part Name	Part No	Part Name	Part No	Part Name
01	Pump Casing	260	Pipe Plug	371	Washer
02	Cover Plate	261	Pipe Plug	372	Washer
04	Suction Flange	262	Pipe Plug	373	Washer
05	Discharge Flange	263	Pipe Plug	374	Washer
06	Fill Cover	264	Pipe Plug	375	Washer
07	Wearing plate	265	Pipe Plug	377	Washer, Impeller
20	Impeller	266	Pipe Plug	380	Suction Flap Valve Pin
30	Bearing Housing	267	Pump Casing Drain Plug	390	Ring
35	Bearing Cover	271	Pressure Relief Valve	391	Ring
50	Stuffing Box	300	Stud	395	Bolt for Lifting
60	Pump Shaft	301	Stud	400	O-Ring
70	Seal Sleeve	320	Hex Bolt	401	O-Ring
72	Mech. Seal Ring	321	Hex Bolt	402	O-Ring
90	Suction Flap Valve	322	Hex Bolt	410	Gasket
91	Suction Flap Valve Part	323	Hex Bolt	411	Gasket
200	Bearing	328	Hex Bolt		
201	Bearing	329	Hex Bolt		
211	Key for Pump Shaft	340	Head Cap Screw Bolt, Impeller		
220	Oil Gasket	361	Nut		
250	Mechanical Seal	370	Washer		

UKM-S Self-Priming Centrifugal Pump Sectional Drawing and Part List (10x10)

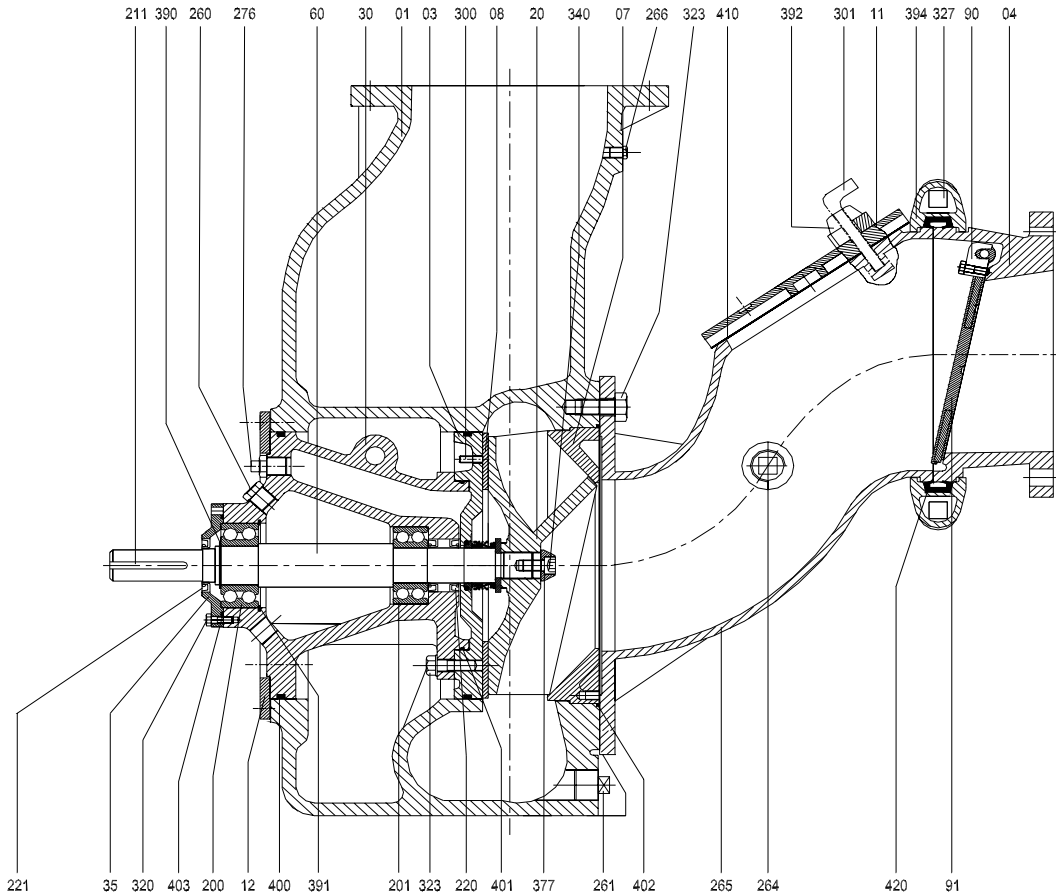

Parts List

Part No	Part Name	Part No	Part Name	Part No	Part Name
01	Pump Casing	200	Ball Bearing	323	Hex Bolt
03	Stuffing Box	201	Ball Bearing	340	Head Cap Screw Bolt, Impeller
04	Suction Flange	211	Key for Pump Shaft	377	Washer, Impeller
07	Wearing Plate	220	Oil Gasket	390	Ring
08	Impeller Back Plate	221	Oil Gasket	391	Ring
11	Elbow Cover	260	Pipe Plug	392	Suction Elbow Cover Part
12	Bearing Housing Flange	261	Pipe Plug	394	Shackle
20	Impeller	264	Pipe Plug	400	O-Ring
30	Bearing Housing	266	Pipe Plug	401	O-Ring
35	Bearing Cover	265	Suction Elbow	402	O-Ring
60	Pump Shaft	300	Stud	403	O-Ring
90	Suction Check Valve Part	301	Stud	410	Gasket
91	Suction Check Valve	320	Hex Bolt	420	Gasket

UKM-S Self-Priming Centrifugal Pump

Rotating Region and Part List

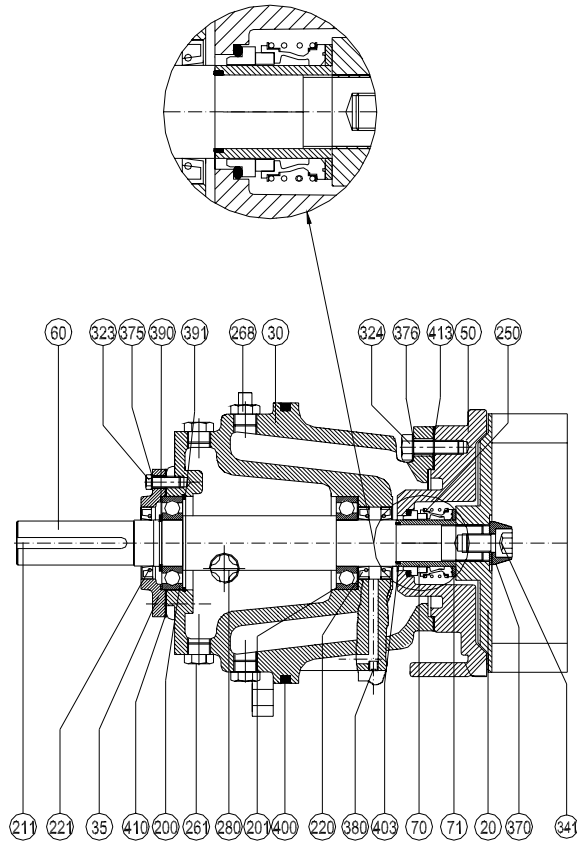

Part No	Part Name	Part No	Part Name
20	Impeller	280	Sight Gauge
30	Bearing Housing	323	Hex Bolt
35	Bearing Cover	324	Hex Bolt
50	Stuffing Box	341	Head Cap Screw Bolt, Impeller
60	Pump Shaft	370	Washer, Impeller
70	Seal Sleeve	375	Washer
71	Seal Ring	376	Washer
200	Bearing	380	Set-Screw
201	Bearing	390	Ring
211	Key for Pump Shaft	391	Ring
220	Oil Gasket	400	O-Ring
221	Oil Gasket	403	O-Ring
250	Mechanical Seal	410	Gasket
261	Pipe Plug	413	Gasket
268	Pipe Plug		

UKM-S Self-Priming Centrifugal Pump

Rotating Region and Part List



Mechanical Seal Specification

BURGMAN MG1

- Single Seal
- Unbalanced
- Elastomer Bellows
- Independent on Direction of Rotation

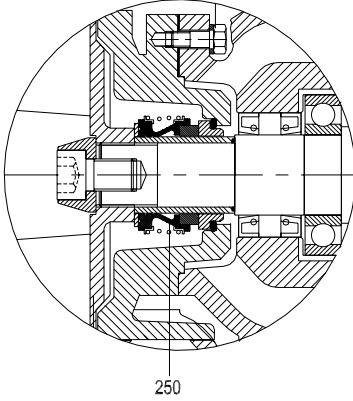

Pump Type	Mechanical Seal	Mech. Seal Dia. (mm)
UKM-S 2x2	MG1	Ø 40
UKM-S 3x3	MG1	Ø 40
UKM-S 4x4	MG1	Ø 40
UKM-S 6x6	MG1	Ø 40
UKM-S 8x8	MG1	Ø 50
UKM-S 10x10	MG1	Ø 50

Bearings

Pump Type	Bearings at impeller side	Bearings at motor side
UKM-S 2"x2"	6208 (SRBB)	6208 (SRBB)
UKM-S 3"x3"	6208 (SRBB)	6208 (SRBB)
UKM-S 4"x4"	6308 (SRBB)	3308 (DRBB)
UKM-S 6"x6"	6308 (SRBB)	3308 (DRBB)
UKM-S 8"x8"	3310 (DRBB)	3311 (DRBB)
UKM-S 10"x10"	3310 (DRBB)	3311 (DRBB)

SRBB: Single Row Ball Bearing
DRBB: Double Row Angular Contact Ball Bearing

Solid Particles

Pump Type	Diameter of Solid Particles
UKM-S 2"x2"	44.5 mm (1.75")
UKM-S 3"x3"	63.5 mm (2.5")
UKM-S 4"x4"	76 mm (3")
UKM-S 6"x6"	76 mm (3")
UKM-S 8"x8"	76 mm (3")
UKM-S 10"x10"	76 mm (3")

Material Options

PUMP TYPE	WEAR PLATE	IMPELLER	CASING	SUCTION COVER VALVE	SEAL HOUSING	BEARING HOUSING	SHAFT	O-RINGS
UKM-S 2X2	STEEL	CI	CI	NEOPRENE	CI	CI	STAINLESS STEEL	VITON NBR
	316 S S	DI	DI	VITON	DI	DI		
UKM-S 3X3	STEEL	CI	CI	NEOPRENE	CI	CI	STAINLESS STEEL	VITON NBR
	316 S S	DI	DI	VITON	DI	DI		
UKM-S 4X4	STEEL	CI	CI	NEOPRENE	CI	CI	STAINLESS STEEL	VITON NBR
	316 S S	DI	DI	VITON	DI	DI		
UKM-S 6X6	STEEL	CI	CI	NEOPRENE	CI	CI	STAINLESS STEEL	VITON NBR
	316 S S	DI	DI	VITON	DI	DI		
UKM-S 8X8	CI	DI	CI	NEOPRENE	CI	CI	STAINLESS STEEL	VITON NBR
	CD4MCu 316 S S	316 S S	DI	VITON	DI	DI		
UKM-S 10X10	DI	DI	CI	NEOPRENE	CI	CI	STAINLESS STEEL	VITON NBR
	316 S S	316 S S	DI	VITON	DI	DI		

CI: Cast Iron, DI:Ductile Cast Iron

UKM-S Self-Priming Centrifugal Pump Automatic Air Release Valve



- ❖ Permits air to escape through the bypass line and then close automatically when the pump is fully primed and pumping at full capacity.
- ❖ During the priming process, air from the pump casing flows through the bypass line and passes through the air release valve to the wet well.

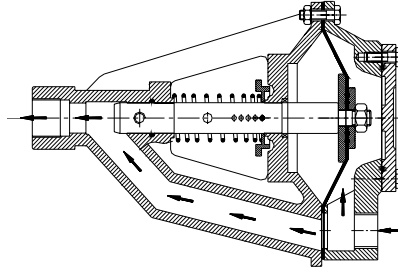

- ❖ When the pump is fully primed, flow pressure compresses the spring and closes the valve.

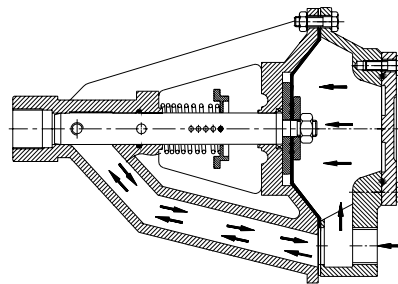

- ❖ When the pump shuts down, the spring returns the diaphragm to its original position.

Cross-Sectional View and Part List

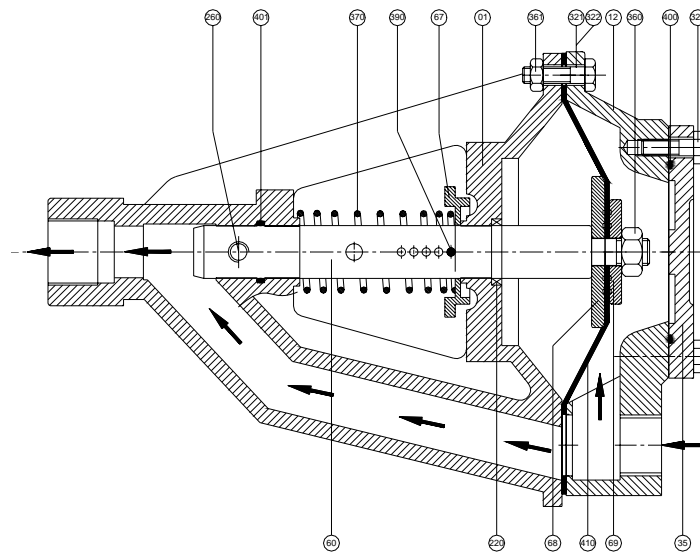

Part List

No	Part Name	No	Part Name
01	Casing	321	Hex Bolt
12	Adapter	322	Hex Bolt
35	Adapter Cover	360	Nut
60	Shaft	361	Nut
67	Spring Sleeve	370	Spring
68	Sleeve	390	Cylindrical Pin
69	Sleeve	400	O-Ring
220	Oil Seal	401	O-Ring
260	Pipe Plug	410	Gasket
320	Hex Bolt		

UKM-S 2"x2" Self-Priming Centrifugal Pump
Performance Curves

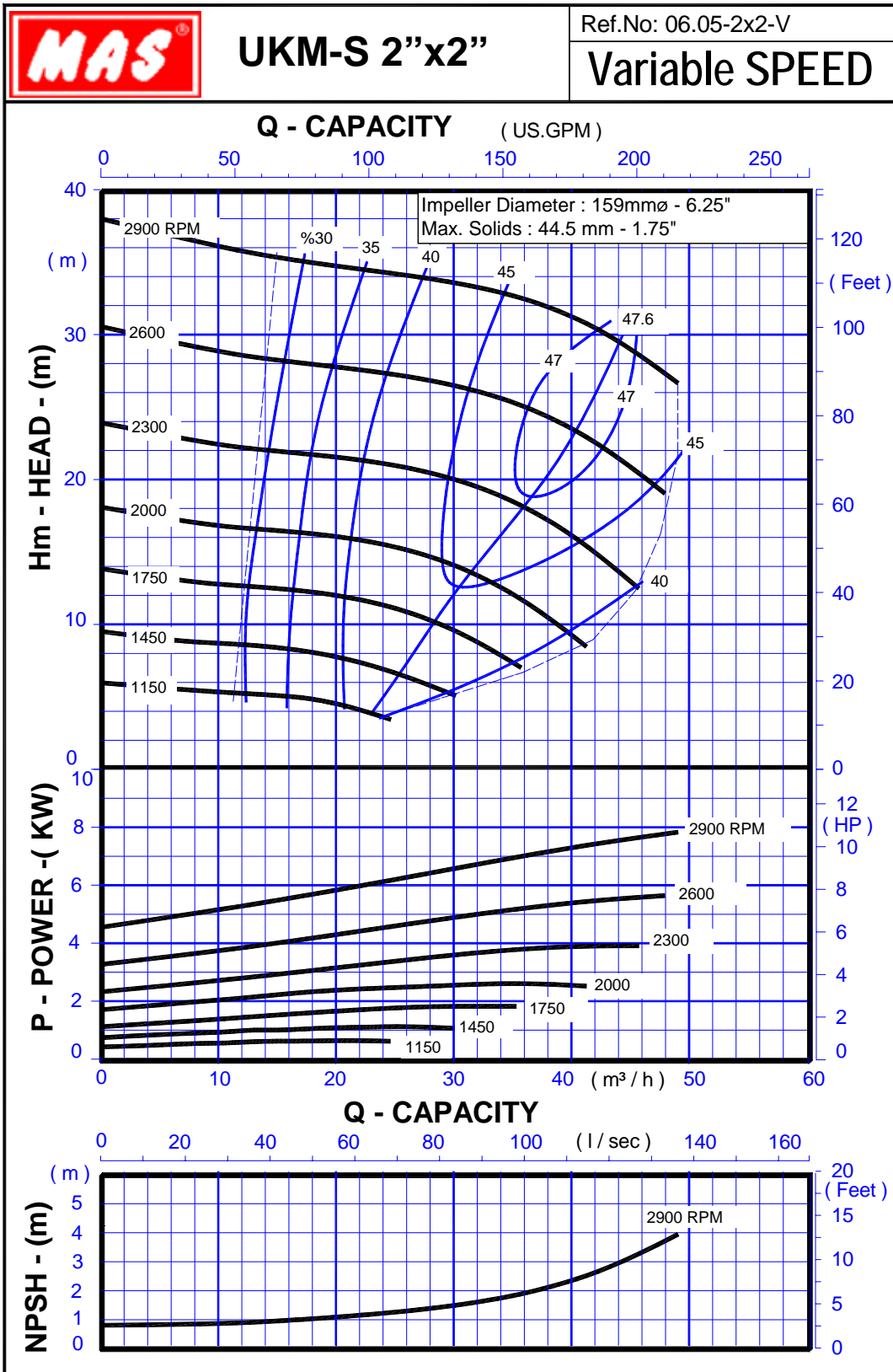

UKM-S 3"x3" Self-Priming Centrifugal Pump
Performance Curves

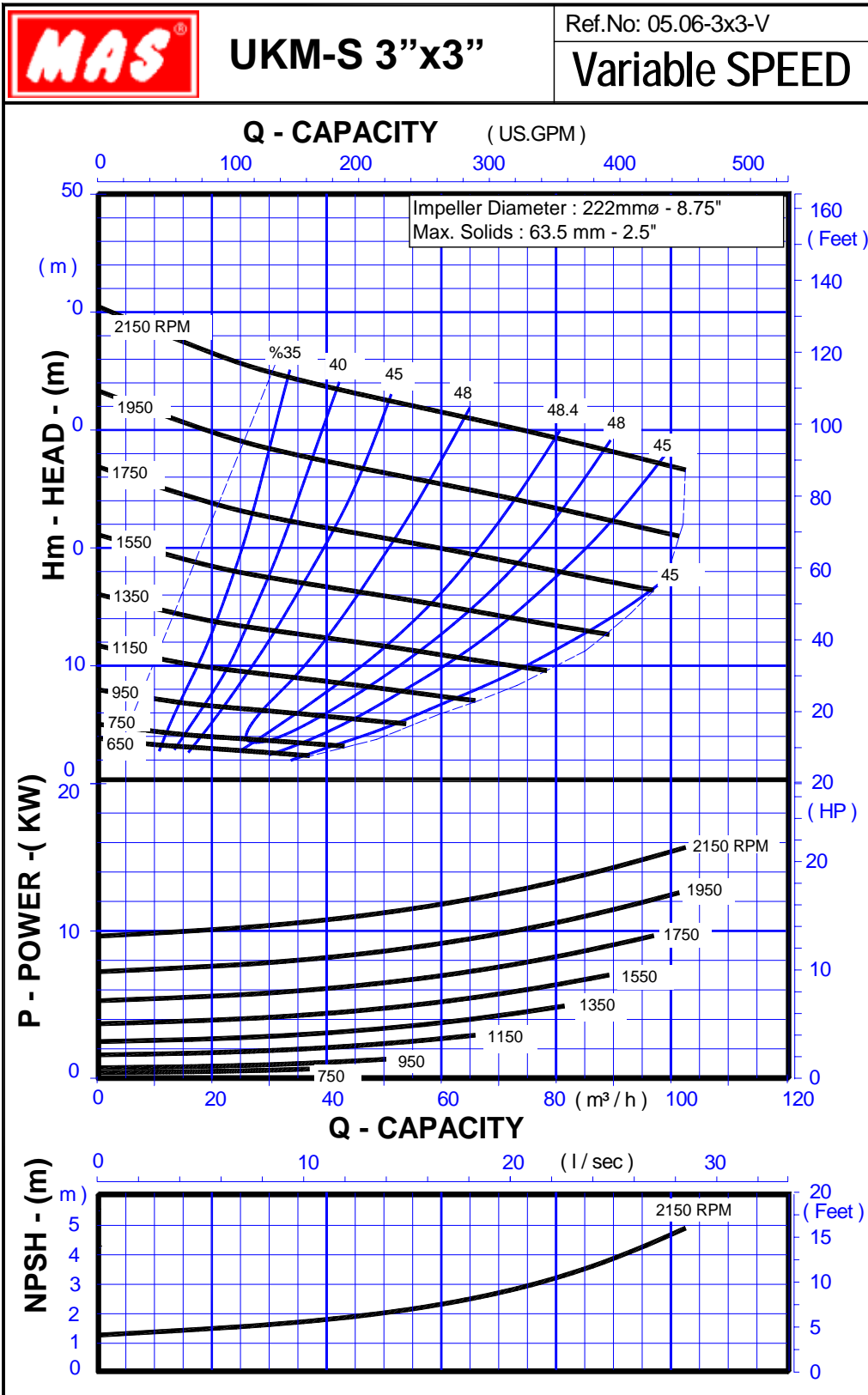

UKM-S 4"x4" Self-Priming Centrifugal Pump
Performance Curves

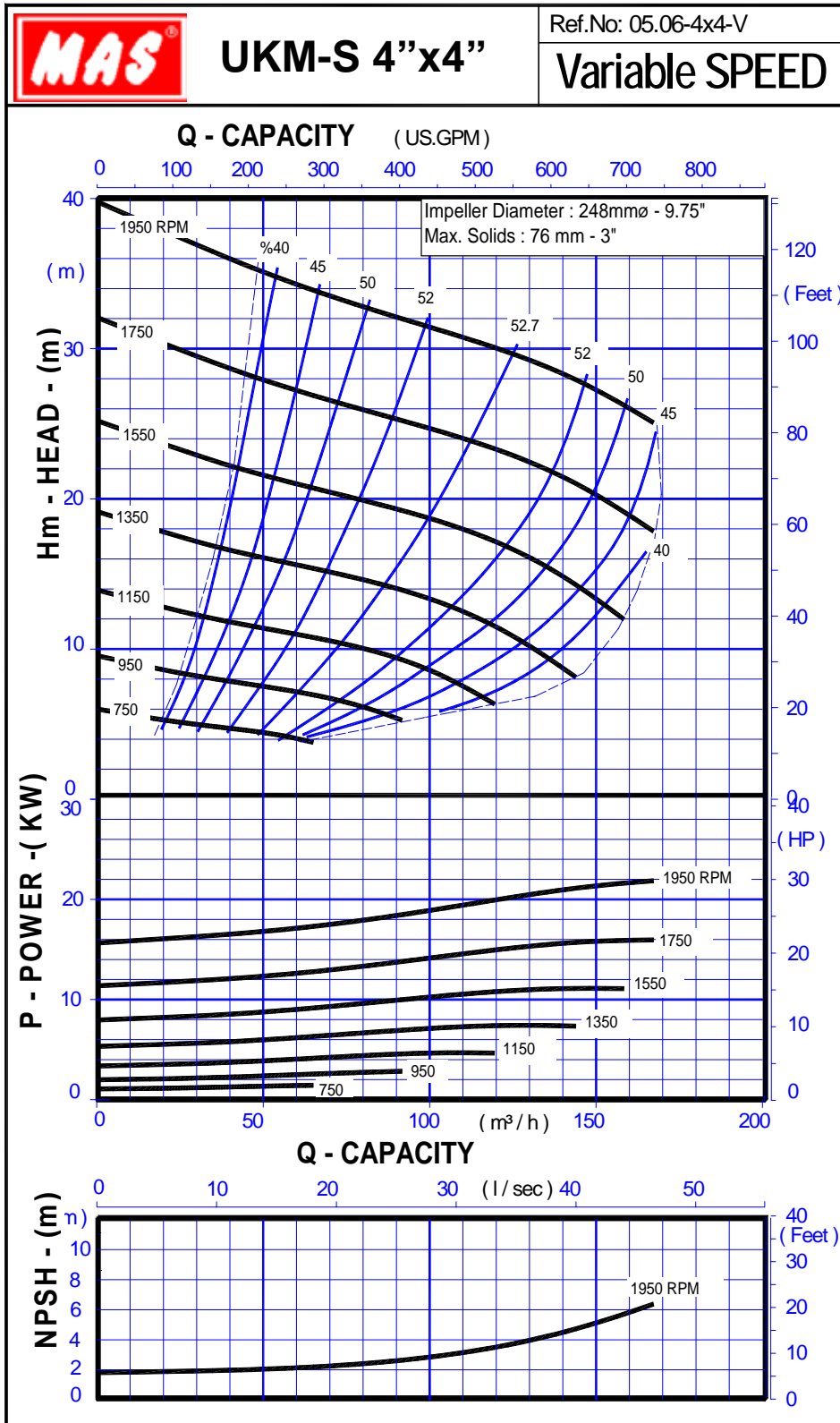

UKM-S 6"x6" Self-Priming Centrifugal Pump Performance Curves

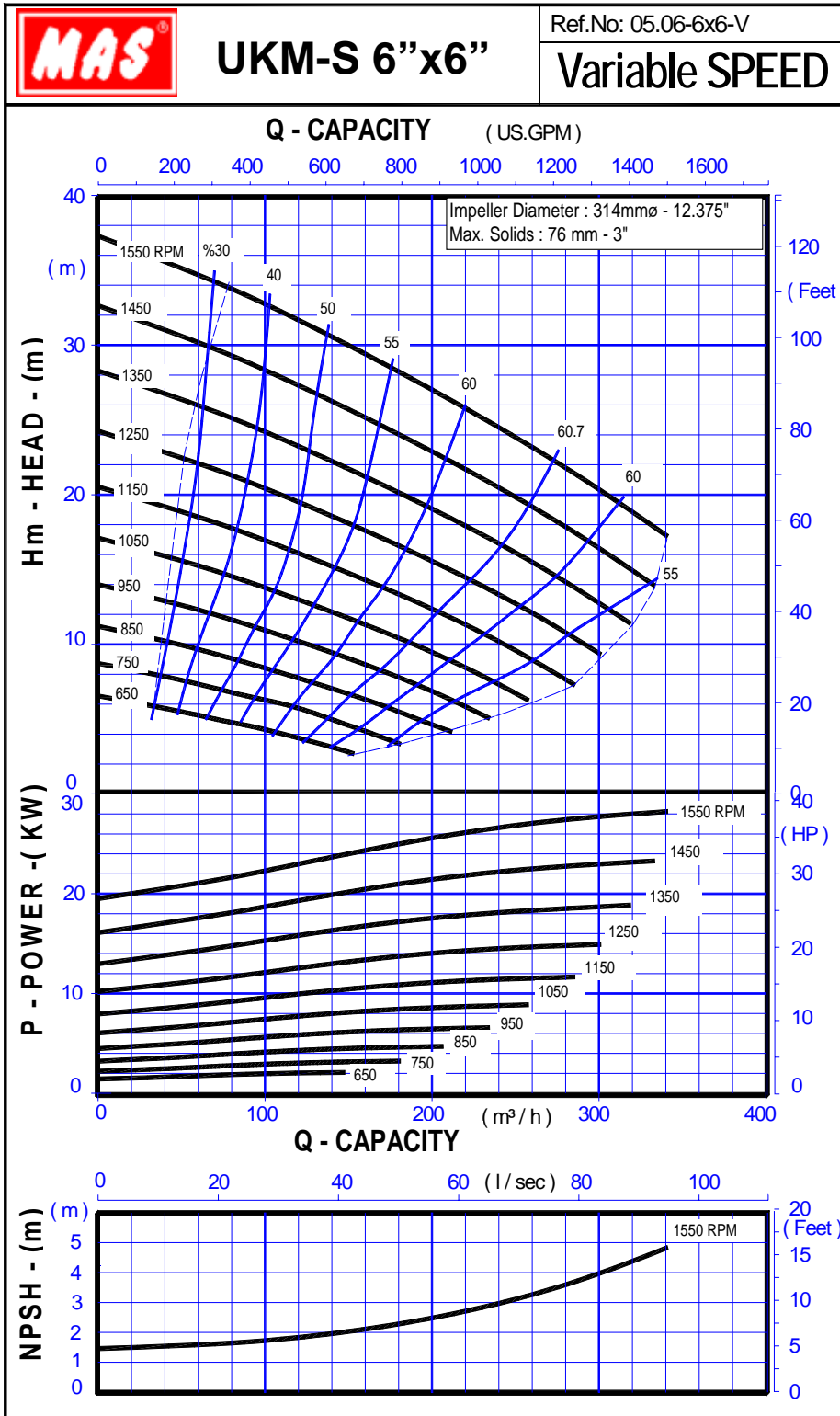

UKM-S 8" x 8" Self-Priming Centrifugal Pump Performance Curves

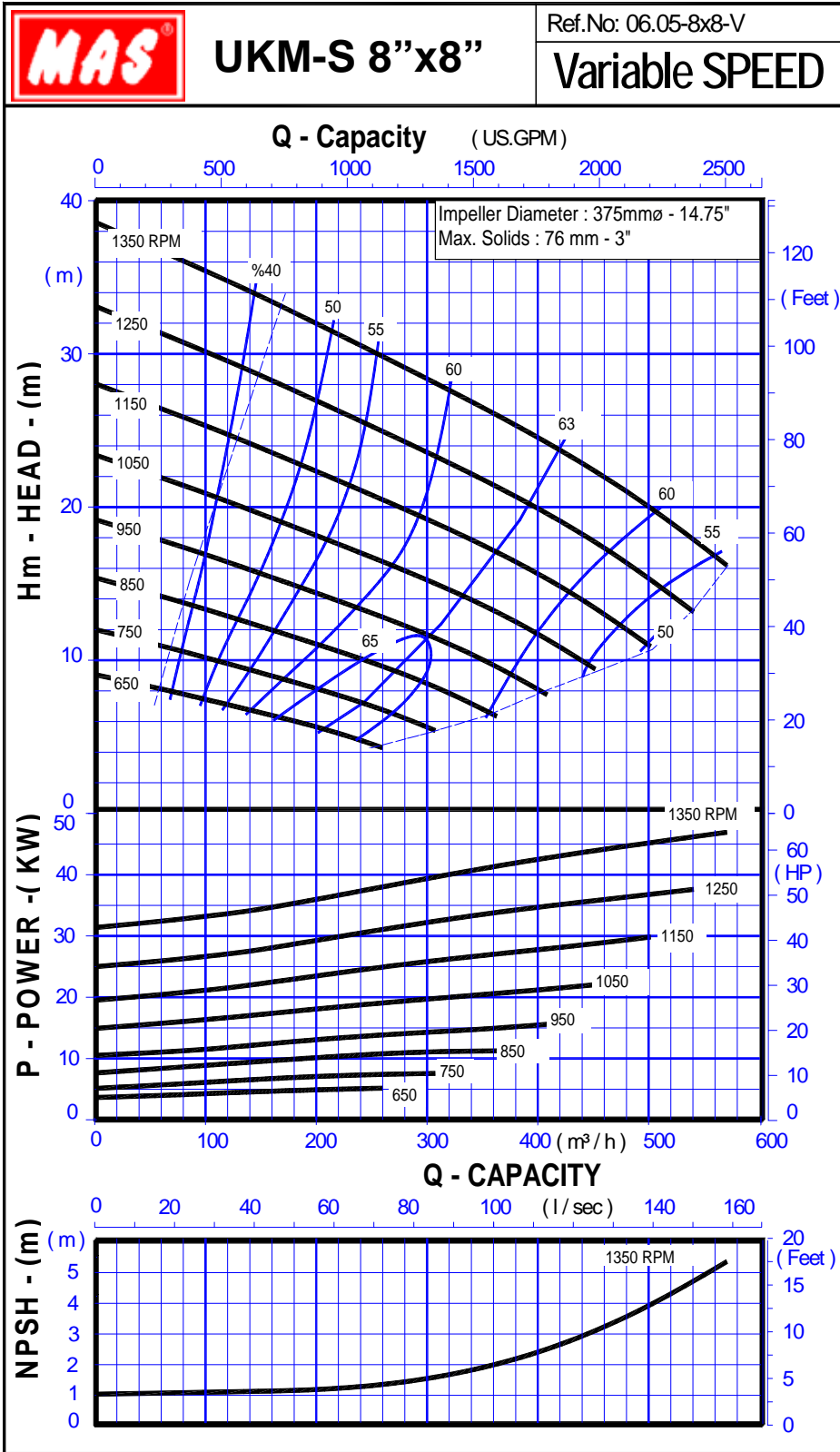

UKM-S 10" x 10" Self-Priming Centrifugal Pump
Performance Curves

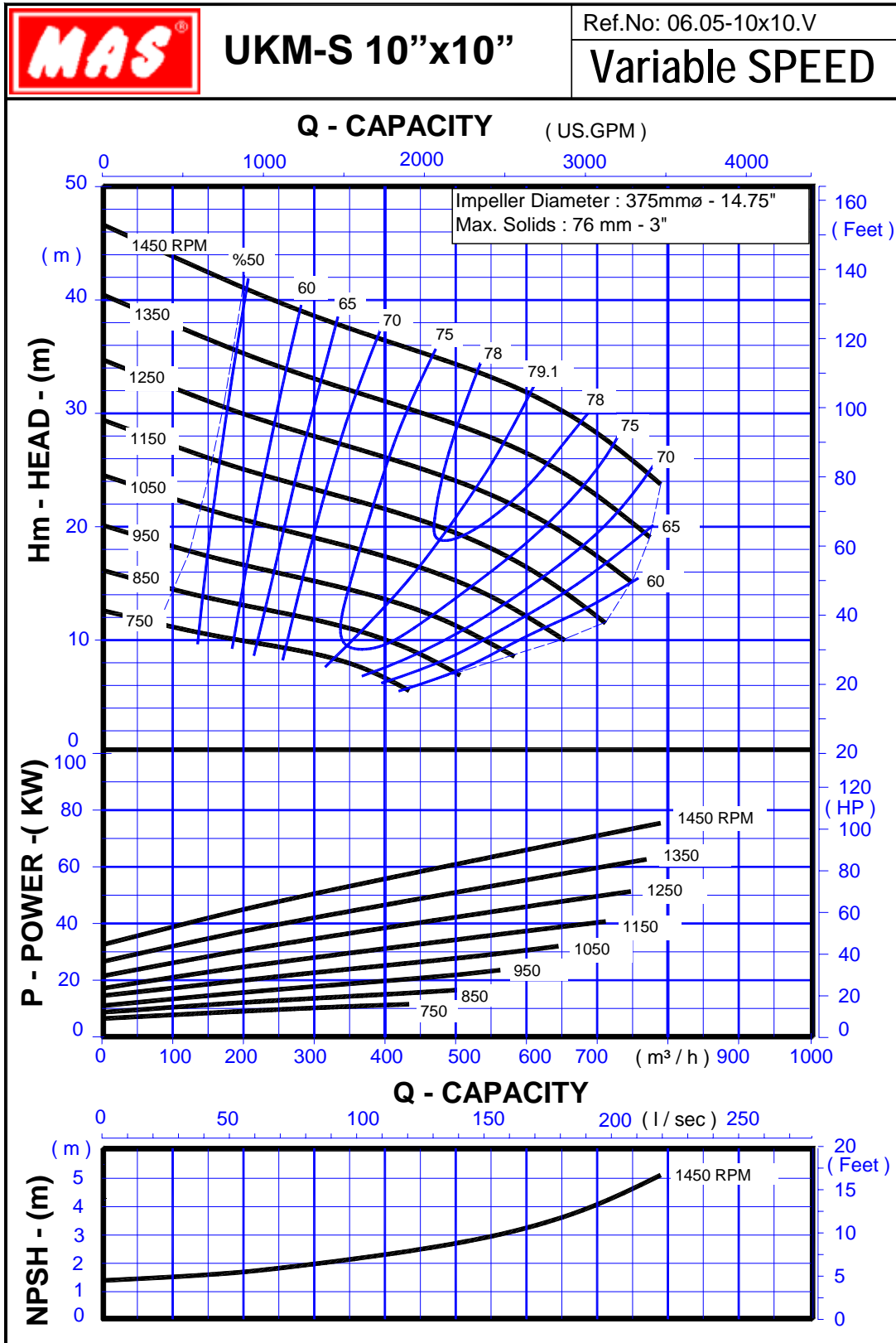

UKM-S Self-Priming Centrifugal Pump

Main Dimensions (50 Hz Electric Motor)

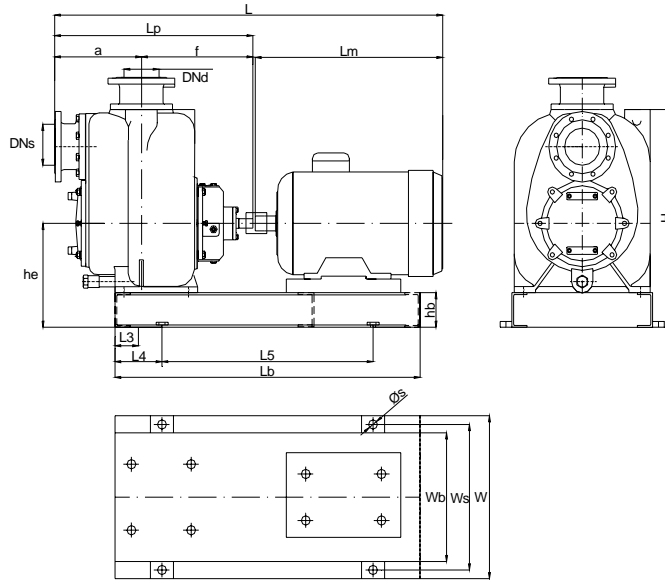

Pump TYPE	Motor			Pump					Foundation Dimensions										
	kw	RPM	hm	Lm	a	f	Lp	L	L3	L4	L5	Lb	Wb	Ws	W	s	H	he	hb
UKM-S 2X2	11	2935	160	601	253	368	621	1245	95	200	600	1000	350	400	450	19	624	250	100
UKM-S 2X2	1.5	1390	90	333	253	368	621	979	95	200	400	800	350	400	450	19	624	250	100
UKM-S 3X3	7.5	1430	132	493	289	436	725	1241	107	200	800	1000	450	500	550	24	783	311	120
UKM-S 3X3	1.5	925	100	375	289	436	725	1123	107	200	550	950	450	500	550	24	783	311	120
UKM-S 4X4	11	1455	160	601	318	499	817	1442	100	200	850	1250	500	550	600	24	855	340	120
UKM-S 4X4	4	940	132	493	318	499	817	1334	100	200	700	1100	500	550	600	24	855	340	120
UKM-S 6X6	30	1450	200	747	413	490	903	1667	236	200	1100	1500	600	650	700	24	1049	378	120
UKM-S 6X6	7.5	960	160	601	413	490	903	1527	236	200	950	1350	600	650	700	24	1049	378	120
UKM-S 8X8	22	975	200	747	406	616	1022	1802	262	300	1050	1650	720	770	820	28	1208	496	160

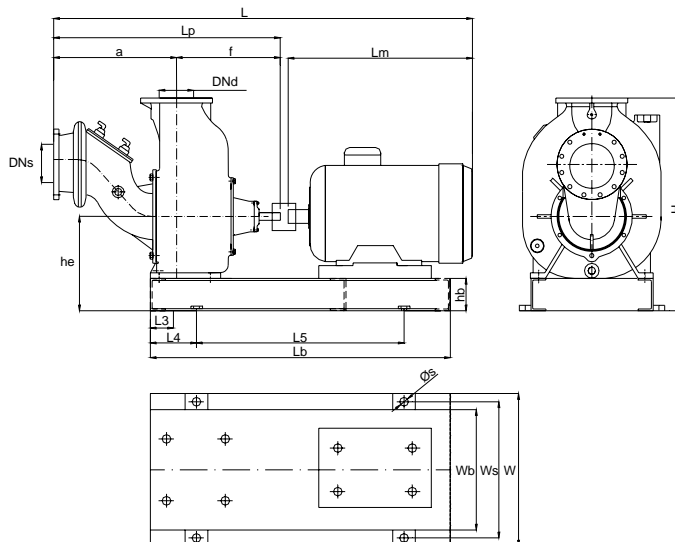

Pump TYPE	Motor			Pump					Foundation Dimensions										
	kw	RPM	hm	Lm	a	f	Lp	L	L3	L4	L5	Lb	Wb	Ws	W	s	H	he	hb
UKM-S 10X10	75	1475	280	958	710	523	1233	2229	151	300	1000	1600	720	770	820	28	1199	516	160
UKM-S 10X10	30	970	225	820	710	523	1233	2081	151	300	900	1500	720	770	820	28	1199	516	160

UKM-S Self-Priming Centrifugal Pump

Main Dimensions (60 Hz Electric Motor)

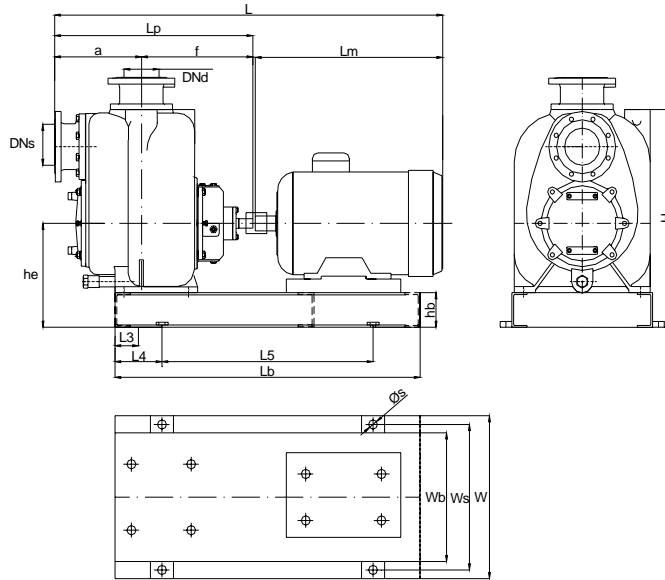

Pump	Motor			Pump					Foundation Dimensions										
TYPE	kw	RPM	hm	Lm	a	f	Lp	L	L3	L4	L5	Lb	Wb	Ws	W	s	H	he	hb
UKM-S 2X2	2.2	1725	100	375	253	368	621	1019	95	200	450	850	350	400	450	19	624	250	100
UKM-S 2X2	1.1	1115	90	340	253	368	621	984	95	200	400	800	350	400	450	19	624	250	100
UKM-S 3X3	11	1755	160	600	289	436	725	1346	107	200	750	1150	450	500	550	24	783	311	120
UKM-S 3X3	4	1160	132	505	289	436	725	1253	107	200	600	1000	450	500	550	24	783	311	120
UKM-S 4X4	18.5	1771	180	690	318	499	817	1531	100	200	1050	1250	500	550	600	24	855	340	120
UKM-S 4X4	7.5	1170	160	600	318	499	817	1441	100	200	1050	1250	500	550	600	24	855	340	120
UKM-S 6X6	15	1177	180	730	413	490	903	1656	236	200	1000	1400	600	650	700	24	1049	378	120
UKM-S 8X8	30	1183	225	835	406	616	1022	1884	262	300	1100	1700	720	770	820	28	1208	496	160

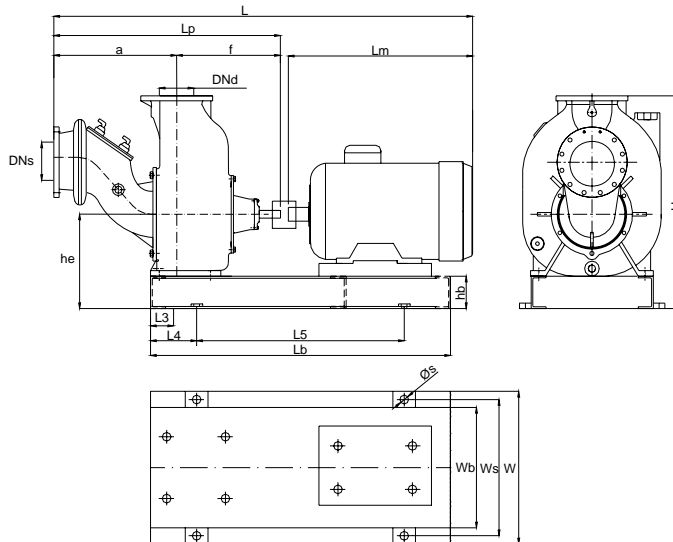

Pump	Motor			Pump					Foundation Dimensions										
TYPE	kw	RPM	hm	Lm	a	f	Lp	L	L3	L4	L5	Lb	Wb	Ws	W	s	H	he	hb
UKM-S 10X10	45	1185	280	985	710	523	1233	2245	151	300	1000	1600	720	770	820	28	1199	516	160

UKM-S 2"x2" Self-Priming Centrifugal Pump

Main Dimensions (50 Hz Electric Motor with V-Belt Application)

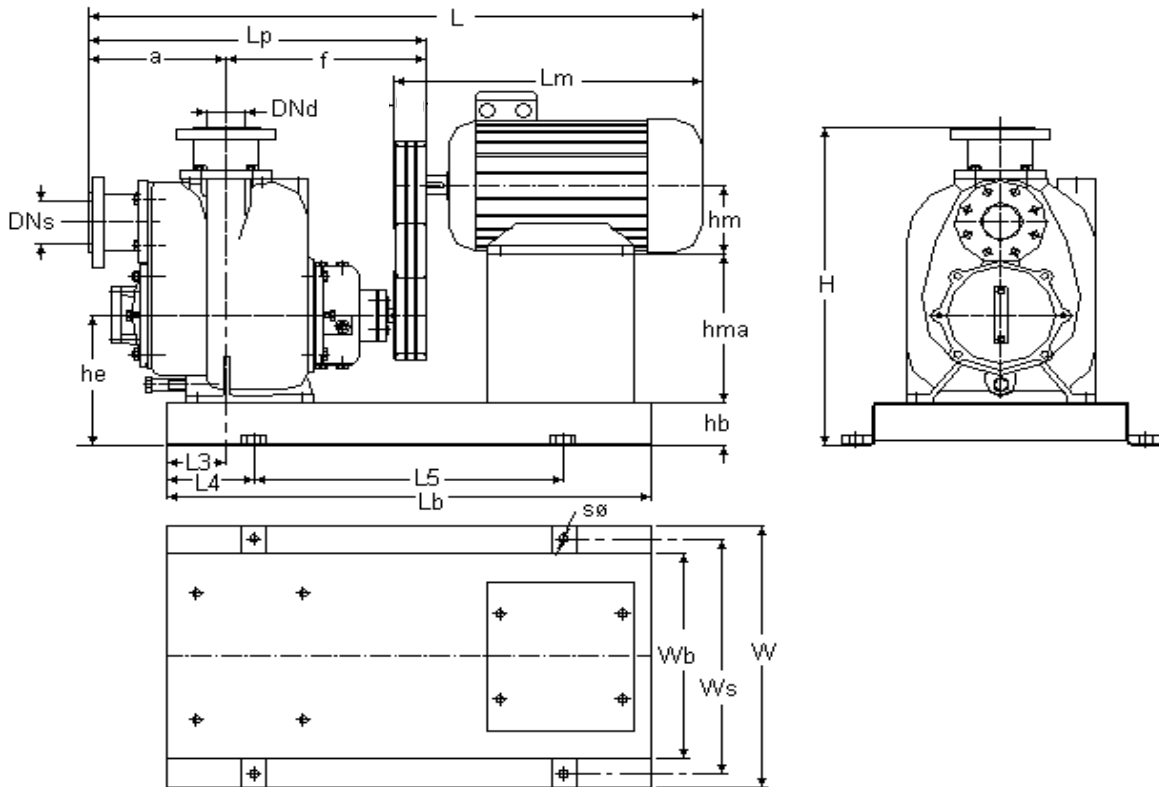

Pump	Motor		Pump					Foundation Dimensions													
RPM	kw	RPM	hm	Lm	a	f	Lp	L	L3	L4	L5	Lb	Wb	Ws	W	s	H	he	hb	hma	
2900	*	*	*	*	*	*	*	*	*	*	*	*	*	*	*	*	*	*	*	*	*
2600	7.5	2935	132	455	253	368	621	1038	95	200	500	950	350	400	450	19	624	250	100	223	
2300	5.5	2870	132	455	253	368	621	1038	95	200	500	950	350	400	450	19	624	250	100	223	
2000	3	1405	100	375	253	368	621	955	95	200	500	900	350	400	450	19	624	250	100	216	
1750	2.2	1400	100	375	253	368	621	955	95	200	500	900	350	400	450	19	624	250	100	210	
1450	*	*	*	*	*	*	*	*	*	*	*	*	*	*	*	*	*	*	*	*	*
1150	1.1	1400	90	308	253	368	621	888	95	200	400	800	350	400	450	19	624	250	100	190	

Pump RPM	Motor Side Belt Pulley Dia. (mm)	Pump Side Belt Pulley Dia. (mm)	Number of V-Belt	Length of V Belts (mm)
2900	*	*	*	*
2600	140	160	2	800
2300	140	175	2	825
2000	110	80	1	550
1750	110	90	1	550
1450	*	*	*	*
1150	80	100	1	475

UKM-S 2"x2" Self-Priming Centrifugal Pump

Main Dimensions (50 Hz Electric Motor with V-Belt Application)

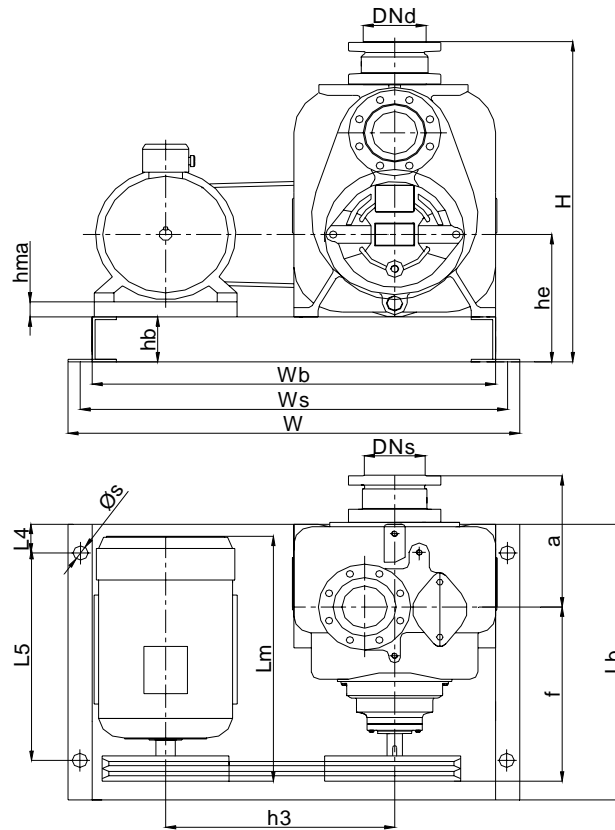

Pump RPM	Motor			Pump			Foundation Dimensions												
	kw	RPM	hm	Lm	a	f	Lp	L4	L5	Lb	Wb	Ws	W	s	H	he	hb	hma	h3
2900	*	*	*	*	*	*	*	*	*	*	*	*	*	*	*	*	*	*	*
2600	7.5	2935	132	455	253	368	621	100	300	500	640	690	740	19	624	250	100	18	357
2300	5.5	2870	132	455	253	368	621	100	300	500	640	690	740	19	624	250	100	18	357
2000	3	1405	100	375	253	368	621	100	300	500	580	630	680	19	624	250	100	50	325
1750	2.2	1400	100	375	253	368	621	100	300	500	580	630	680	19	624	250	100	50	320
1450	*	*	*	*	*	*	*	*	*	*	*	*	*	*	*	*	*	*	*
1150	1.1	1400	90	308	253	368	621	100	300	500	550	600	650	19	624	250	100	60	300

Pump RPM	Motor Side Belt Pulley Dia. (mm)	Pump Side Belt Pulley Dia. (mm)	Number of V-Belt	Length of V- Belts (mm)
2900	*	*	*	*
2600	140	160	2	1100
2300	140	175	2	1125
2000	110	80	1	875
1750	110	90	1	875
1450	*	*	*	*
1150	80	100	1	800

UKM-S 3"x3" Self-Priming Centrifugal Pump

Main Dimensions (50 Hz Electric Motor with V-Belt Application)

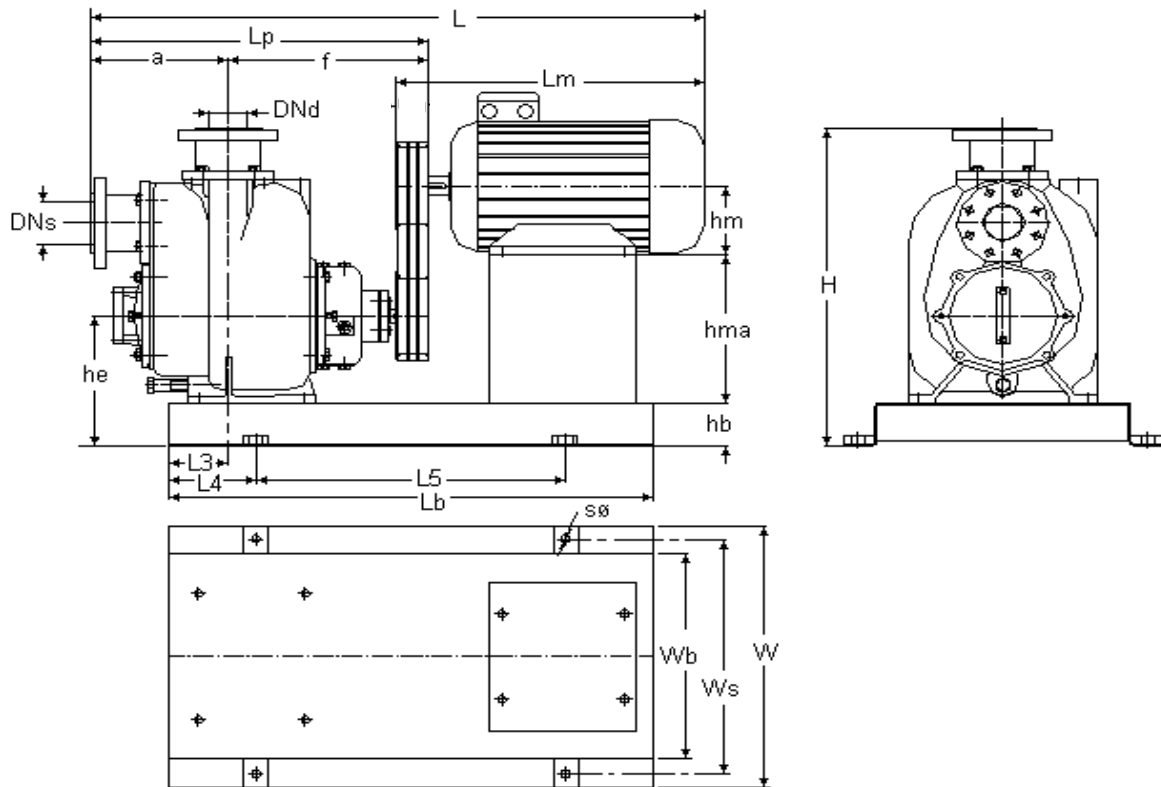

Pump RPM	Motor		Pump						Foundation Dimensions											
	kw	RPM	hm	Lm	a	f	Lp	L	L3	L4	L5	Lb	Wb	Ws	W	s	H	he	hb	hma
2150	18.5	2940	160	645	289	436	725	1330	107	200	800	1200	450	500	550	24	783	311	120	311
1950	15	1460	160	645	289	436	725	1330	107	200	800	1200	450	500	550	24	783	311	120	226
1750	11	1455	160	601	289	436	725	1285	107	200	800	1150	450	500	550	24	783	311	120	226
1550	7.5	1430	132	493	289	436	725	1178	107	200	800	1000	450	500	550	24	783	311	120	249
1350	5.5	1430	132	493	289	436	725	1178	107	200	800	1000	450	500	550	24	783	311	120	249
1150	4	1420	112	423	289	436	725	1078	107	200	800	900	450	500	550	24	783	311	120	274
950	*	*	*	*	*	*	*	*	*	*	*	*	*	*	*	*	*	*	*	*
750	1.1	915	90	333	289	436	725	1018	107	200	800	900	450	500	550	24	783	311	120	246

Pump RPM	Motor Side Belt Pulley Dia. (mm)	Pump Side Belt Pulley Dia. (mm)	Number of V-Belt	Length of Belts (mm)
2150	200	270	4	1225
1950	190	140	4	825
1750	175	140	3	800
1550	150	140	3	750
1350	140	150	2	750
1150	140	175	2	800
950	*	*	*	*
750	90	110	2	525

UKM-S 3"x3" Self-Priming Centrifugal Pump

Main Dimensions (50 Hz Electric Motor with V-Belt Application)

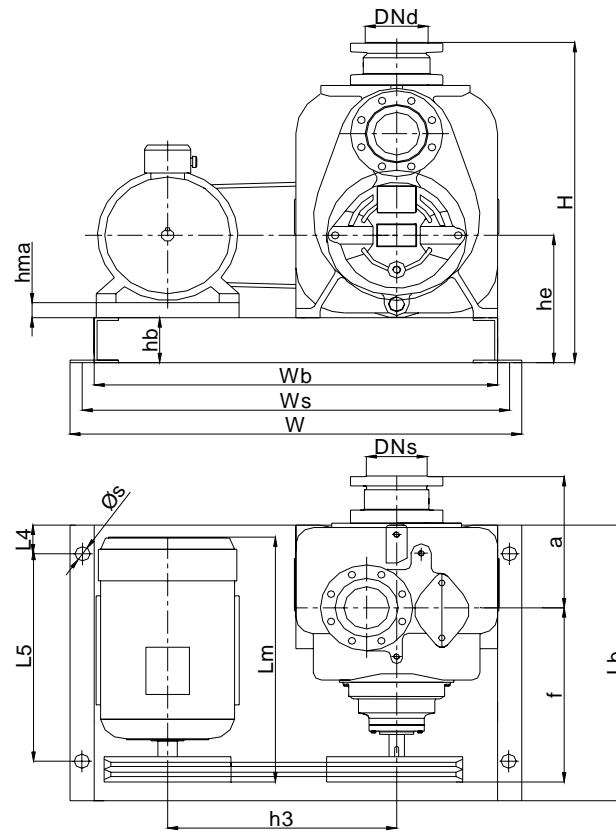

Pump	Motor				Pump			Foundation Dimensions												
	RPM	kw	RPM	hm	Lm	a	f	Lp	L4	L5	Lb	Wb	Ws	W	s	H	he	hb	hma	h3
2150	18.5	2940	160	645	289	436	725	100	440	640	910	960	1010	24	783	311	120	31	530	
1950	15	1460	160	645	289	436	725	100	440	640	910	960	1010	24	783	311	120	31	530	
1750	11	1455	160	601	289	436	725	100	440	640	910	960	1010	24	783	311	120	31	530	
1550	7.5	1430	132	493	289	436	725	100	440	640	850	900	950	24	783	311	120	59	500	
1350	5.5	1430	132	493	289	436	725	100	440	640	850	900	950	24	783	311	120	59	500	
1150	4	1420	112	423	289	436	725	100	440	640	820	870	920	24	783	311	120	79	480	
950	*	*	*	*	*	*	*	*	*	*	*	*	*	*	*	*	*	*	*	*

Pump RPM	Motor Side Belt Pulley Dia. (mm)	Pump Side Belt Pulley Dia. (mm)	Number of V-Belt	Length of V-Belts (mm)
2150	200	270	4	1725
1950	190	140	4	1500
1750	175	140	3	1475
1550	150	140	3	1375
1350	140	150	2	1375
1150	140	175	2	1375
950	*	*	*	*

UKM-S 4"x4" Self-Priming Centrifugal Pump

Main Dimensions (50 Hz Electric Motor with V-Belt Application)

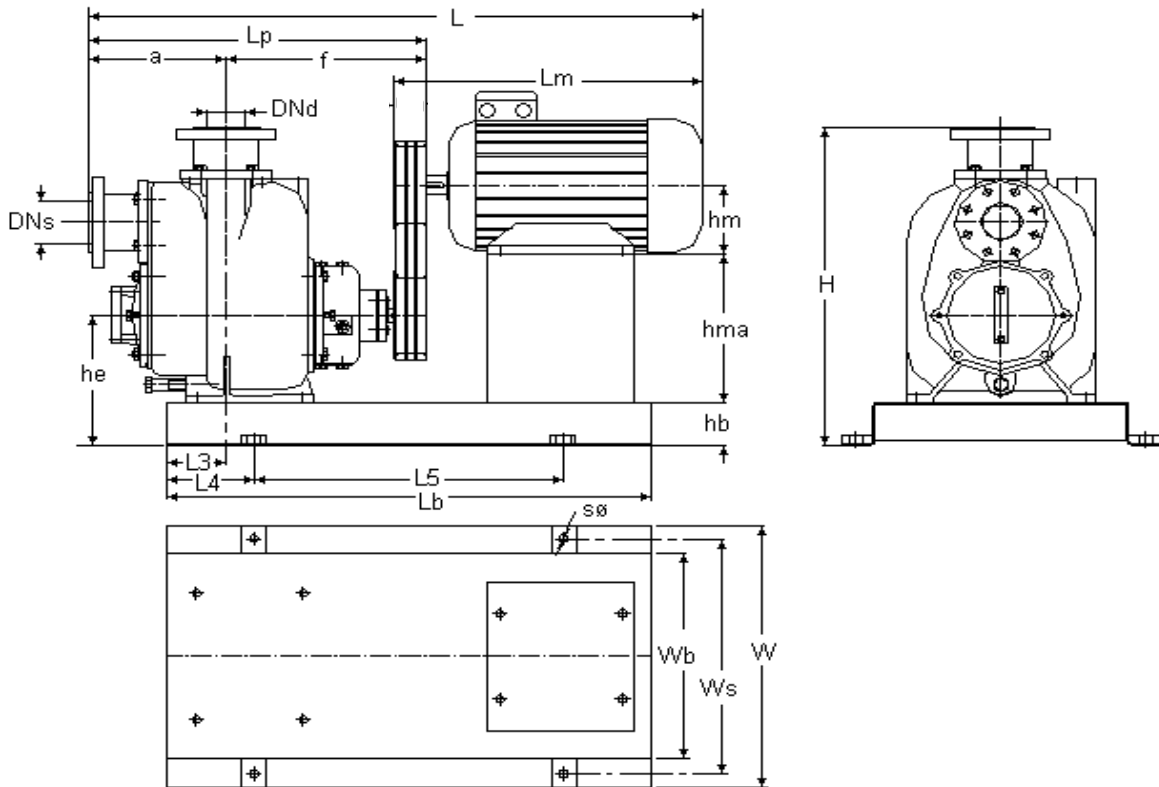

Pump RPM	Motor			Pump				Foundation Dimensions												
	kw	RPM	hm	Lm	a	f	Lp	L	L3	L4	L5	Lb	Wb	Ws	W	s	H	he	hb	hma
1950	22	1460	180	697	318	499	817	1475	100	200	850	1250	500	550	600	24	855	340	120	280
1750	18.5	1460	180	659	318	499	817	1437	100	200	850	1250	500	550	600	24	855	340	120	280
1550	15	1460	160	645	318	499	817	1422	100	200	850	1250	500	550	600	24	855	340	120	280
1350	11	1455	160	601	318	499	817	1378	100	200	850	1250	500	550	600	24	855	340	120	280
1150	7.5	1455	132	493	318	499	817	1270	100	200	750	1150	500	550	600	24	855	340	120	308
950	*	*	*	*	*	*	*	*	*	*	*	*	*	*	*	*	*	*	*	*
750	2.2	940	100	394	318	499	817	1171	100	200	650	1050	500	550	600	24	855	340	120	323

Pump RPM	Motor Side Belt Pulley Dia. (mm)	Pump Side Belt Pulley Dia. (mm)	Number of V-Belt	Length of V Belts (mm)
1950	190	140	4	875
1750	180	150	4	875
1550	190	175	4	925
1350	175	190	3	925
1150	140	175	3	850
950	*	*	*	*
750	150	175	1	850

UKM-S 4"x4" Self-Priming Centrifugal Pump
Main Dimensions (50 Hz Electric Motor with V-Belt Application)

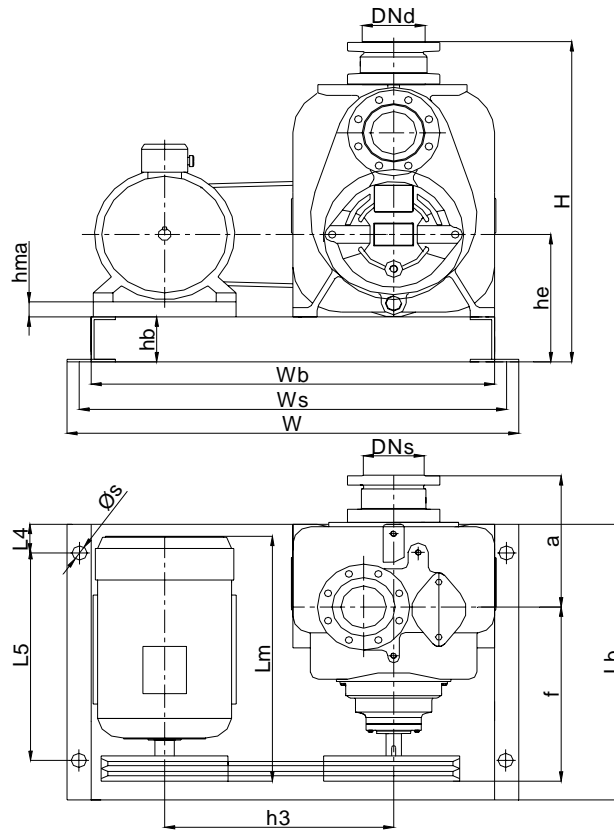

Pump RPM	Motor			Pump			Foundation Dimensions												
	kw	RPM	hm	Lm	a	f	Lp	L4	L5	Lb	Wb	Ws	W	s	H	he	hb	hma	h3
1950	22	1460	180	697	318	499	817	100	540	740	1000	1050	1100	24	855	340	120	40	568
1750	18.5	1460	180	659	318	499	817	100	540	740	1000	1050	1100	24	855	340	120	40	568
1550	15	1460	160	645	318	499	817	100	540	740	970	1020	1070	24	855	340	120	60	555
1350	11	1455	160	601	318	499	817	100	540	740	970	1020	1070	24	855	340	120	60	555
1150	7.5	1455	132	493	318	499	817	100	540	740	910	960	1010	24	855	340	120	88	530
950	*	*	*	*	*	*	*	*	*	*	*	*	*	*	*	*	*	*	*
750	2.2	940	112	394	318	499	817	100	540	740	880	930	980	24	855	340	120	108	113

Pump RPM	Motor Side Belt Pulley Dia. (mm)	Pump Side Belt Pulley Dia. (mm)	Number of V-Belt	Length of V-Belts (mm)
1950	190	140	4	1575
1750	180	150	4	1575
1550	190	175	4	1600
1350	175	190	3	1600
1150	140	175	3	1475
950	*	*	*	*
750	150	175	1	1450

UKM-S 6"x6" Self-Priming Centrifugal Pump

Main Dimensions (50 Hz Electric Motor with V-Belt Application)

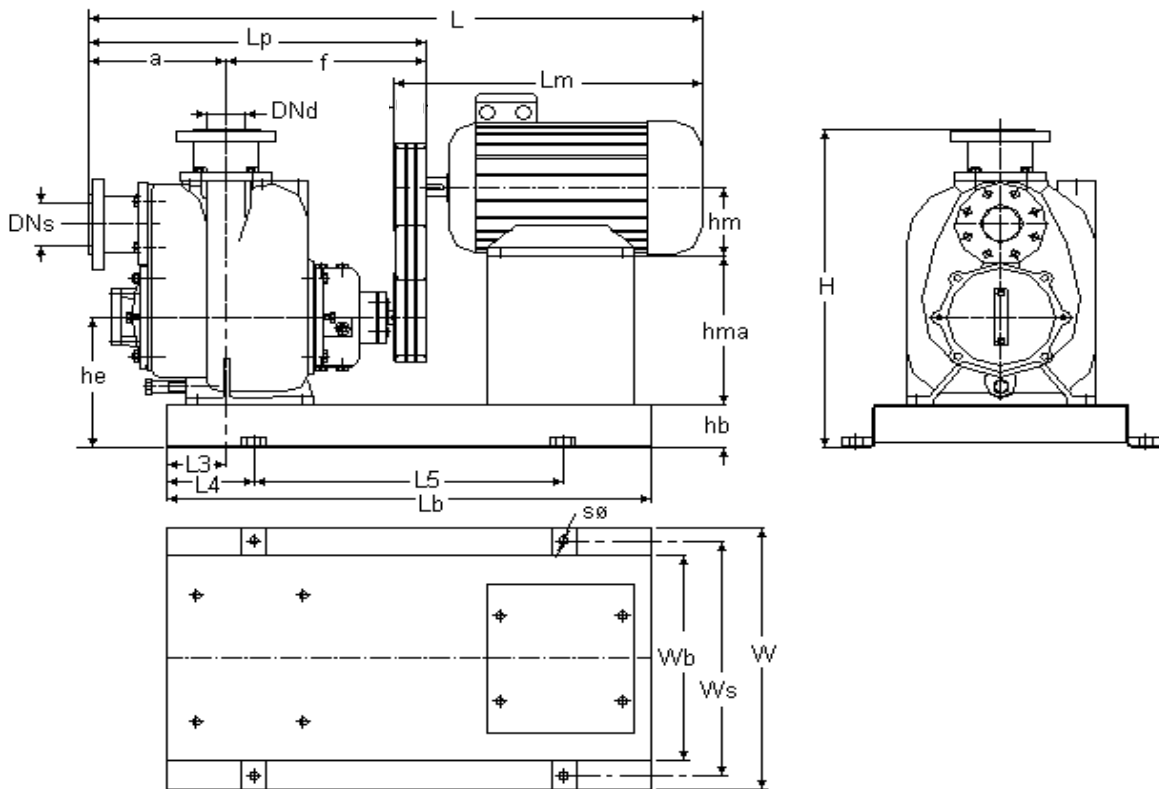

Pump RPM	Motor		Pump						Foundation Dimensions											
	kw	RPM	hm	Lm	a	f	Lp	L	L3	L4	L5	Lb	Wb	Ws	W	s	H	he	hb	hma
1550	30	1460	200	747	413	490	903	1610	236	200	1100	1500	600	650	700	24	1049	378	120	343
1450	*	*	*	*	*	*	*	*	*	*	*	*	*	*	*	*	*	*	*	*
1350	22	1460	180	697	413	490	903	1560	236	200	1100	1500	600	650	700	24	1049	378	120	313
1250	18.5	1460	180	659	413	490	903	1522	236	200	1000	1400	600	650	700	24	1049	378	120	328
1150	15	1460	160	645	413	490	903	1507	236	200	1000	1400	600	650	700	24	1049	378	120	348
1050	11	1455	160	601	413	490	903	1464	236	200	900	1300	600	650	700	24	1049	378	120	353
950	*	*	*	*	*	*	*	*	*	*	*	*	*	*	*	*	*	*	*	*
850	5.5	945	132	493	413	490	903	1355	236	200	900	1300	600	650	700	24	1049	378	120	341
750	4	940	132	493	413	490	903	1355	236	200	900	1300	600	650	700	24	1049	378	120	346
650	3	945	132	455	413	490	903	1318	236	200	900	1300	600	650	700	24	1049	378	120	351

Pump RPM	Motor Side Belt Pulley Dia. (mm)	Pump Side Belt Pulley Dia. (mm)	Number of V-Belt	Length of Belts (mm)
1550	260	240	4	1275
1450	*	*	*	*
1350	180	190	4	975
1250	190	225	4	1075
1150	180	225	4	1050
1050	175	240	3	1075
950	*	*	*	*
850	160	175	3	875
750	140	175	2	850
650	140	200	2	900

UKM-S 6"x6" Self-Priming Centrifugal Pump

Main Dimensions (50 Hz Electric Motor with V-Belt Application)

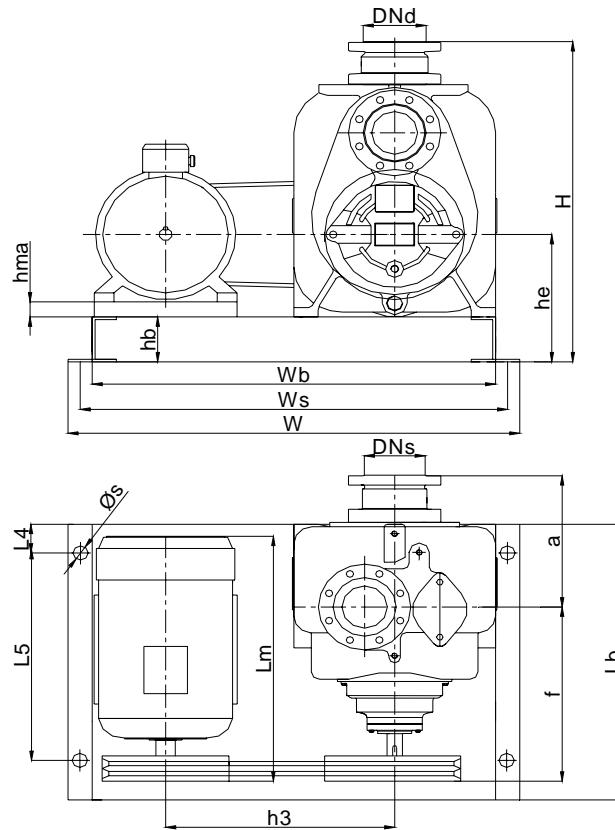

Pump RPM	Motor			Pump			Foundation Dimensions												
	kw	RPM	hm	Lm	a	f	Lp	L4	L5	Lb	Wb	Ws	W	s	H	he	hb	hma	h3
1550	30	1460	200	747	413	490	903	100	540	740	1130	1180	1230	24	1049	378	120	58	635
1450	*	*	*	*	*	*	*	*	*	*	*	*	*	*	*	*	*	*	*
1350	22	1460	180	697	413	490	903	100	540	740	1090	1140	1190	24	1049	378	120	78	612
1250	18.5	1460	180	659	413	490	903	100	540	740	1100	1150	1200	24	1049	378	120	78	625
1150	15	1460	160	645	413	490	903	100	540	740	1055	1105	1155	24	1049	378	120	98	599
1050	11	1455	160	601	413	490	903	100	540	740	1055	1105	1155	24	1049	378	120	98	602
950	*	*	*	*	*	*	*	*	*	*	*	*	*	*	*	*	*	*	*
850	5.5	945	132	493	413	490	903	100	540	740	1000	1050	1100	24	1049	378	120	126	566
750	4	940	132	493	413	490	903	100	540	740	1000	1050	1100	24	1049	378	120	126	569
650	3	945	132	455	413	490	903	100	540	740	1000	1050	1100	24	1049	378	120	126	572

Pump RPM	Motor Side Belt Pulley Dia. (mm)	Pump Side Belt Pulley Dia. (mm)	Number of V-Belt	Length of V-Belts (mm)
1550	260	240	4	1975
1450	*	*	*	*
1350	180	190	4	1725
1250	190	225	4	1825
1150	180	225	4	1750
1050	175	240	3	1775
950	*	*	*	*
850	160	175	3	1575
750	140	175	2	1550
650	140	200	2	1600

UKM-S 8"x8" Self-Priming Centrifugal Pump

Main Dimensions (50 Hz Electric Motor with V-Belt Application)

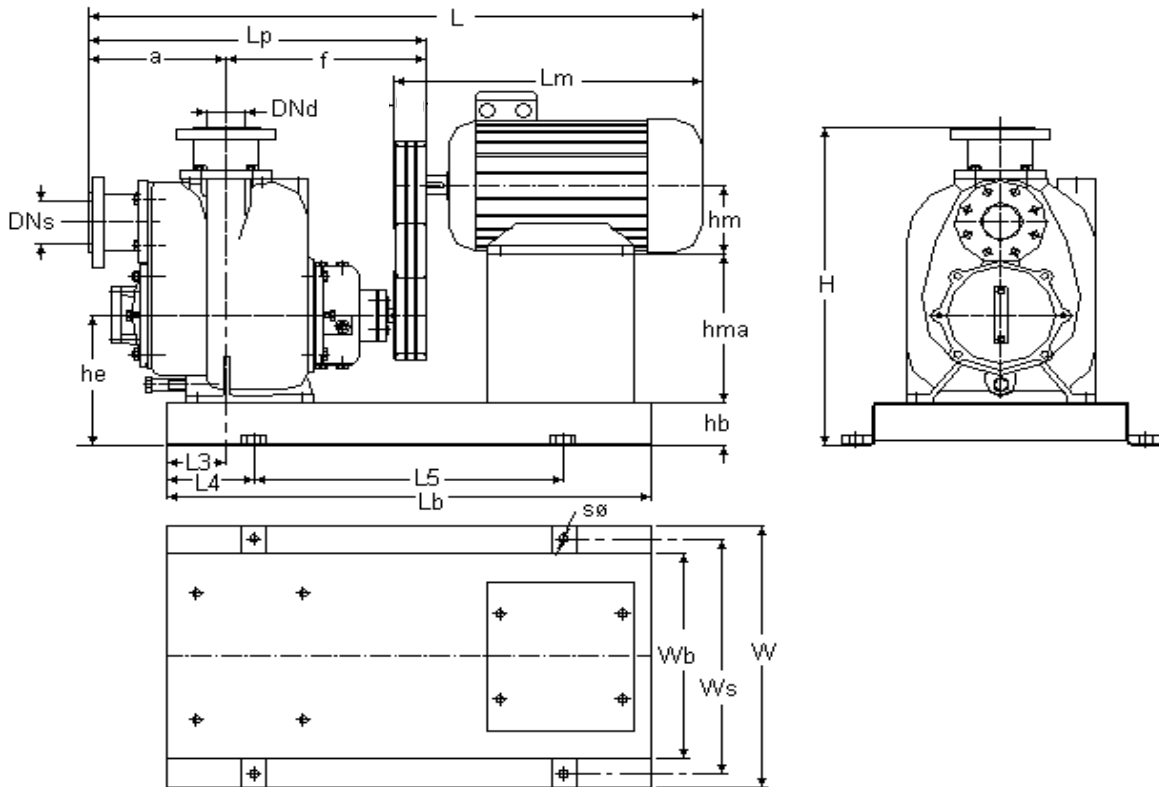

Pump RPM	Motor		Pump						Foundation Dimensions											
	kw	RPM	hm	Lm	a	f	Lp	L	L3	L4	L5	Lb	Wb	Ws	W	s	H	he	hb	hma
1350	55	1470	250	900	406	616	1022	1872	262	300	1100	1700	720	770	820	28	1208	496	160	426
1250	45	1465	225	820	406	616	1022	1792	262	300	1100	1700	720	770	820	28	1208	496	160	468
1150	30	1460	200	747	406	616	1022	1719	262	300	1100	1700	720	770	820	28	1208	496	160	481
1050	22	1460	180	697	406	616	1022	1670	262	300	1000	1600	720	770	820	28	1208	496	160	411
950	*	*	*	*	*	*	*	*	*	*	*	*	*	*	*	*	*	*	*	*
850	15	960	180	697	406	616	1022	1670	262	300	1000	1600	720	770	820	28	1208	496	160	396
750	11	955	160	645	406	616	1022	1617	262	300	900	1500	720	770	820	28	1208	496	160	426
650	7.5	960	160	601	406	616	1022	1573	262	300	900	1500	720	770	820	28	1208	496	160	431

Pump RPM	Motor Side Belt Pulley Dia. (mm)	Pump Side Belt Pulley Dia. (mm)	Number of V-Belt	Length of Belts (mm)
1350	275	300	5	1500
1250	300	350	4	1700
1150	260	325	4	1525
1050	180	250	4	1100
950	*	*	*	*
850	180	200	4	1000
750	180	225	4	1050
650	175	250	3	1100

UKM-S 8"x8" Self-Priming Centrifugal Pump

Main Dimensions (50 Hz Electric Motor with V-Belt Application)

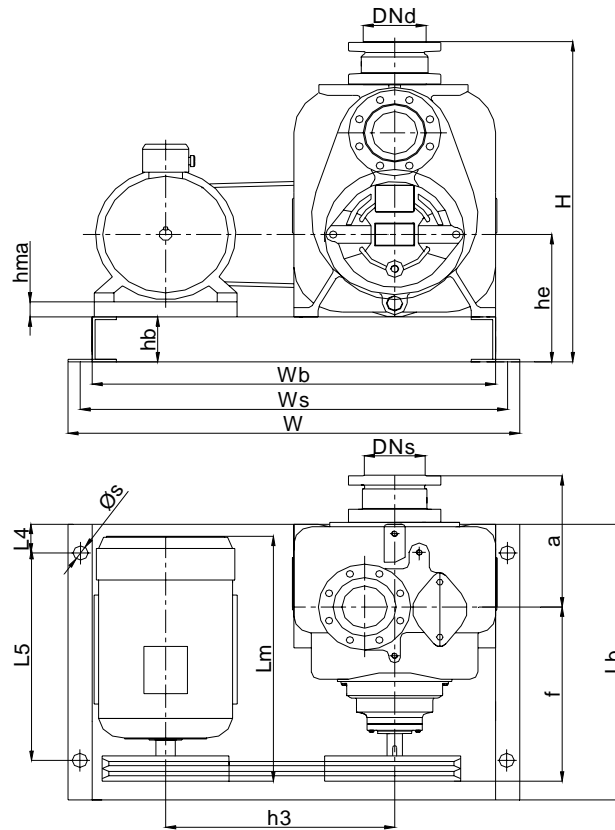

Pump RPM	Motor		Pump					Foundation Dimensions											
	kw	RPM	hm	Lm	a	f	Lp	L4	L5	Lb	Wb	Ws	W	s	H	he	hb	hma	h3
1350	55	1470	250	900	406	616	1022	200	550	950	1340	1390	1440	28	1208	496	160	86	740
1250	45	1465	225	820	406	616	1022	200	550	950	1300	1350	1400	28	1208	496	160	111	720
1150	30	1460	200	747	406	616	1022	200	550	950	1290	1340	1390	28	1208	496	160	136	730
1050	22	1460	180	697	406	616	1022	200	550	950	1210	1260	1310	28	1208	496	160	156	678
950	*	*	*	*	*	*	*	*	*	*	*	*	*	*	*	*	*	*	*
850	15	960	180	697	406	616	1022	200	550	950	1210	1260	1310	28	1208	496	160	156	680
750	11	955	160	645	406	616	1022	200	550	950	1170	1220	1270	28	1208	496	160	176	660
650	7.5	960	160	601	406	616	1022	200	550	950	1170	1220	1270	28	1208	496	160	176	656

Pump RPM	Motor Side Belt Pulley Dia. (mm)	Pump Side Belt Pulley Dia. (mm)	Number of V-Belt	Length of V-Belts (mm)
1350	275	300	5	2300
1250	300	350	4	2380
1150	260	325	4	2300
1050	180	250	4	1950
950	*	*	*	*
850	180	200	4	1875
750	180	225	4	1875
650	175	250	3	1875

UKM-S 10"x10" Self-Priming Centrifugal Pump
Main Dimensions (50 Hz Electric Motor with V-Belt Application)

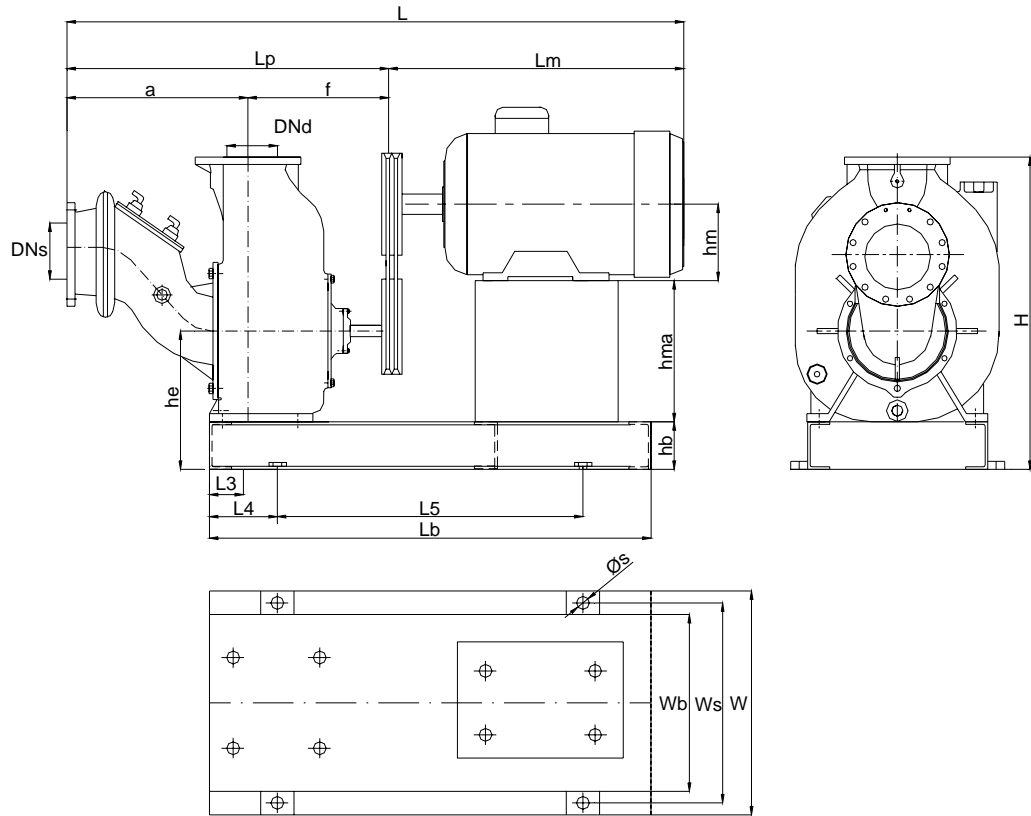

Pump RPM	Motor		Pump					Foundation Dimensions												
	kw	RPM	hm	Lm	a	f	Lp	L	L3	L4	L5	Lb	Wb	Ws	W	s	H	he	hb	hma
1450	*	*	*	*	*	*	*	*	*	*	*	*	*	*	*	*	*	*	*	*
1350	75	1475	280	958	710	523	1233	2141	151	300	1000	1600	720	770	820	28	1199	516	160	451
1250	55	1470	250	900	710	523	1233	2083	151	300	950	1550	720	770	820	28	1199	516	160	481
1150	45	1465	225	820	710	523	1233	2003	151	300	850	1450	720	770	820	28	1199	516	160	541
1050	37	1465	225	795	710	523	1233	1978	151	300	850	1450	720	770	820	28	1199	516	160	501
950	*	*	*	*	*	*	*	*	*	*	*	*	*	*	*	*	*	*	*	*
850	18.5	970	200	747	710	523	1233	1930	151	300	850	1450	720	770	820	28	1199	516	160	467
750	15	960	180	697	710	523	1233	1880	151	300	850	1450	720	770	820	28	1199	516	160	426

Pump RPM	Motor Side Belt Pulley Dia. (mm)	Pump Side Belt Pulley Dia. (mm)	Number of V-Belt	Length of Belts (mm)
1450	*	*	*	*
1350	325	350	6	1725
1250	300	350	5	1700
1150	300	375	4	1750
1050	250	350	5	1550
950	*	*	*	*
850	240	275	4	1325
750	180	225	4	1050

UKM-S 10"x10" Self-Priming Centrifugal Pump
Main Dimensions (50 Hz Electric Motor with V-Belt Application)

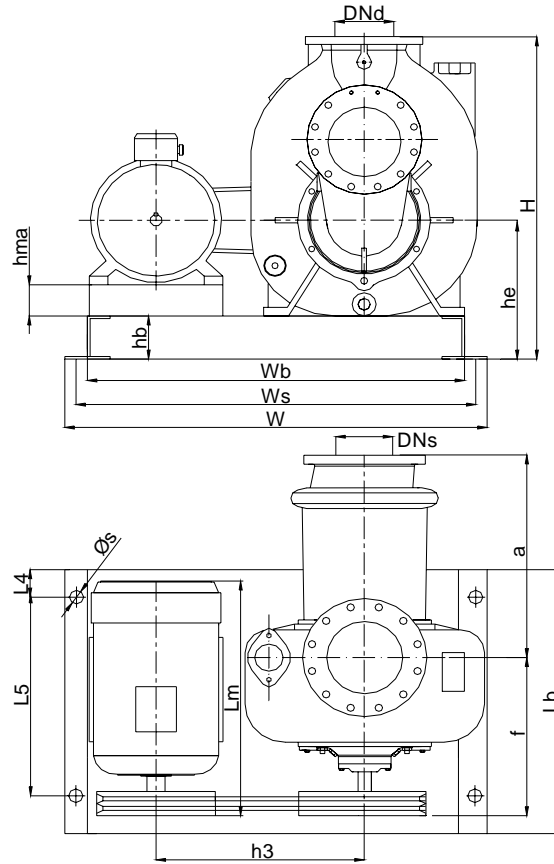

Pump RPM	Motor				Pump			Foundation Dimensions											
	kw	RPM	hm	Lm	a	f	Lp	L4	L5	Lb	Wb	Ws	W	s	H	he	hb	hma	h3
1450	*	*	*	*	*	*	*	*	*	*	*	*	*	*	*	*	*	*	*
1350	75	1475	280	958	710	523	1233	200	440	840	1470	1520	1570	28	1199	516	160	76	833
1250	55	1470	250	900	710	523	1233	200	390	790	1390	1440	1490	28	1199	516	160	106	792
1150	45	1465	225	820	710	523	1233	200	390	790	1350	1400	1450	28	1199	516	160	131	772
1050	37	1465	225	795	710	523	1233	200	390	790	1340	1390	1440	28	1199	516	160	131	767
950	*	*	*	*	*	*	*	*	*	*	*	*	*	*	*	*	*	*	*
850	18.5	970	200	747	710	523	1233	200	390	790	1300	1350	1400	28	1199	516	160	156	737
750	15	960	180	697	710	523	1233	200	390	790	1260	1310	1360	28	1199	516	160	176	724

Pump RPM	Motor Side Belt Pulley Dia. (mm)	Pump Side Belt Pulley Dia. (mm)	Number of V-Belt	Length of V-Belts (mm)
1450	*	*	*	*
1350	325	350	6	2645
1250	300	350	5	2525
1150	300	375	4	2525
1050	250	350	5	2400
950	*	*	*	*
850	240	275	4	2200
750	180	225	4	2000

UKM-S 2"x2" Self-Priming Centrifugal Pump
Main Dimensions (60 Hz Electric Motor with V-Belt Application)

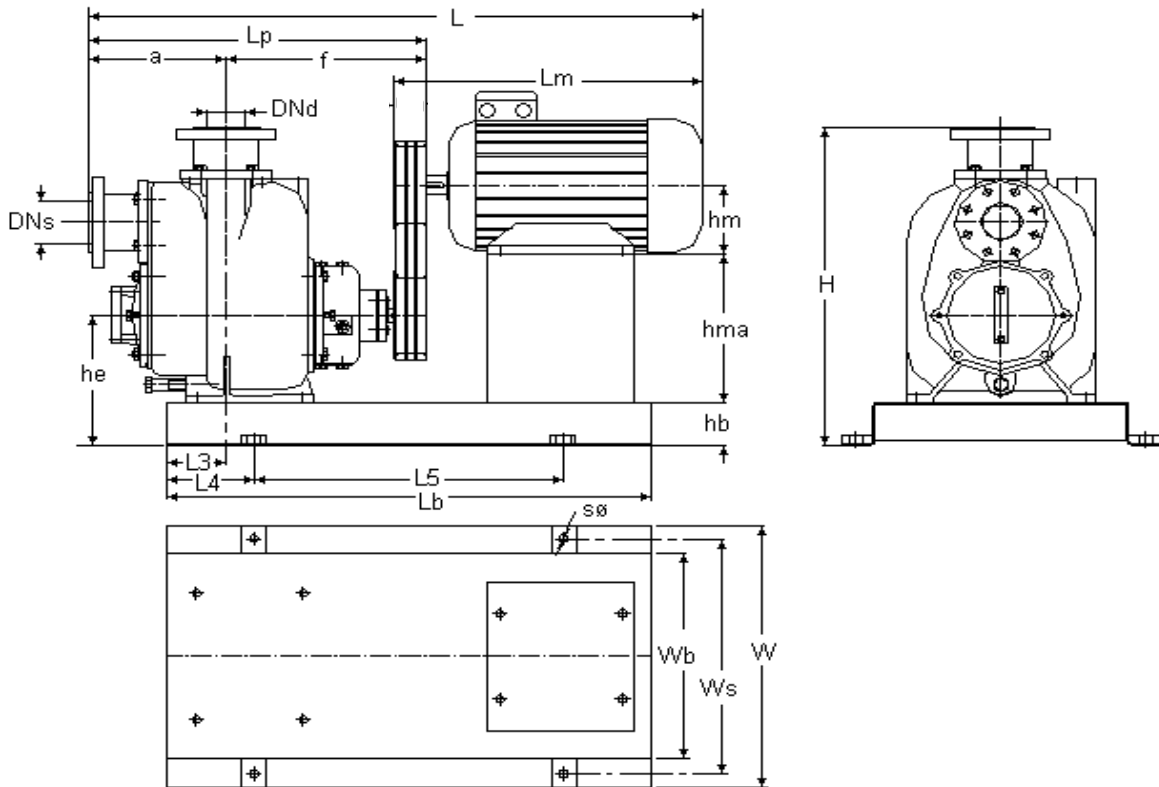

Pump	Motor		Pump						Foundation Dimensions											
	RPM	kw	RPM	hm	Lm	a	f	Lp	L	L3	L4	L5	Lb	Wb	Ws	W	s	H	he	hb
2900	11.0	3530	160	600	253	368	621	1180	95	200	700	1100	350	400	450	19	624	250	100	211
2600	7.5	3495	132	465	253	368	621	1045	95	200	550	950	350	400	450	19	624	250	100	243
2300	5.5	1750	132	465	253	368	621	1045	95	200	550	950	350	400	450	19	624	250	100	203
2000	3	1710	100	375	253	368	621	955	95	200	400	800	350	400	450	19	624	250	100	200
1750	*	*	*	*	*	*	*	*	*	*	*	*	*	*	*	*	*	*	*	*
1450	1.5	1690	90	340	253	368	621	955	95	200	400	800	350	400	450	19	624	250	100	190
1150	*	*	*	*	*	*	*	*	*	*	*	*	*	*	*	*	*	*	*	*

Pump RPM	Motor Side Belt Pulley Dia. (mm)	Pump Side Belt Pulley Dia. (mm)	Number of V-Belt	Length of V-Belts (mm)
2900	160	200	3	925
2600	150	200	2	925
2300	140	106	2	675
2000	112	95	2	525
1750	*	*	*	*
1450	90	106	1	500
1150	*	*	*	*

UKM-S 2"x2" Self-Priming Centrifugal Pump

Main Dimensions (60 Hz Electric Motor with V-Belt Application)

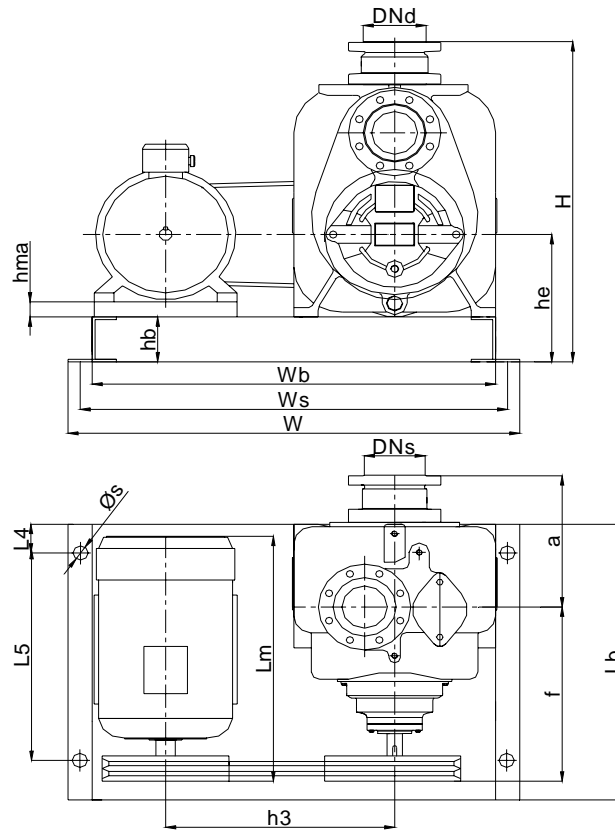

Pump RPM	Motor		Pump					Foundation Dimensions											
	kw	RPM	hm	Lm	a	f	Lp	L4	L5	Lb	Wb	Ws	W	s	H	he	hb	hma	h3
2900	11	3530	160	600	253	368	621	100	300	500	770	820	870	19	624	250	100	10	456
2600	7.5	3495	132	465	253	368	621	100	300	500	650	700	750	19	624	250	100	18	367
2300	5.5	1750	132	465	253	368	621	100	300	500	640	690	740	19	624	250	100	18	357
2000	3	1710	100	375	253	368	621	100	300	500	580	630	680	19	624	250	100	50	325
1750	*	*	*	*	*	*	*	*	*	*	*	*	*	*	*	*	*	*	*
1450	1.5	1690	90	340	253	368	621	100	300	500	550	600	650	19	624	250	100	60	300
1150	*	*	*	*	*	*	*	*	*	*	*	*	*	*	*	*	*	*	*

Pump RPM	Motor Side Belt Pulley Dia. (mm)	Pump Side Belt Pulley Dia. (mm)	Number of V-Belt	Length of V-Belts (mm)
2900	160	200	3	1425
2600	150	200	2	1200
2300	140	106	2	1025
2000	112	95	2	900
1750	*	*	*	*
1450	90	106	1	825
1150	*	*	*	*

UKM-S 3"x3" Self-Priming Centrifugal Pump

Main Dimensions (60 Hz Electric Motor with V-Belt Application)

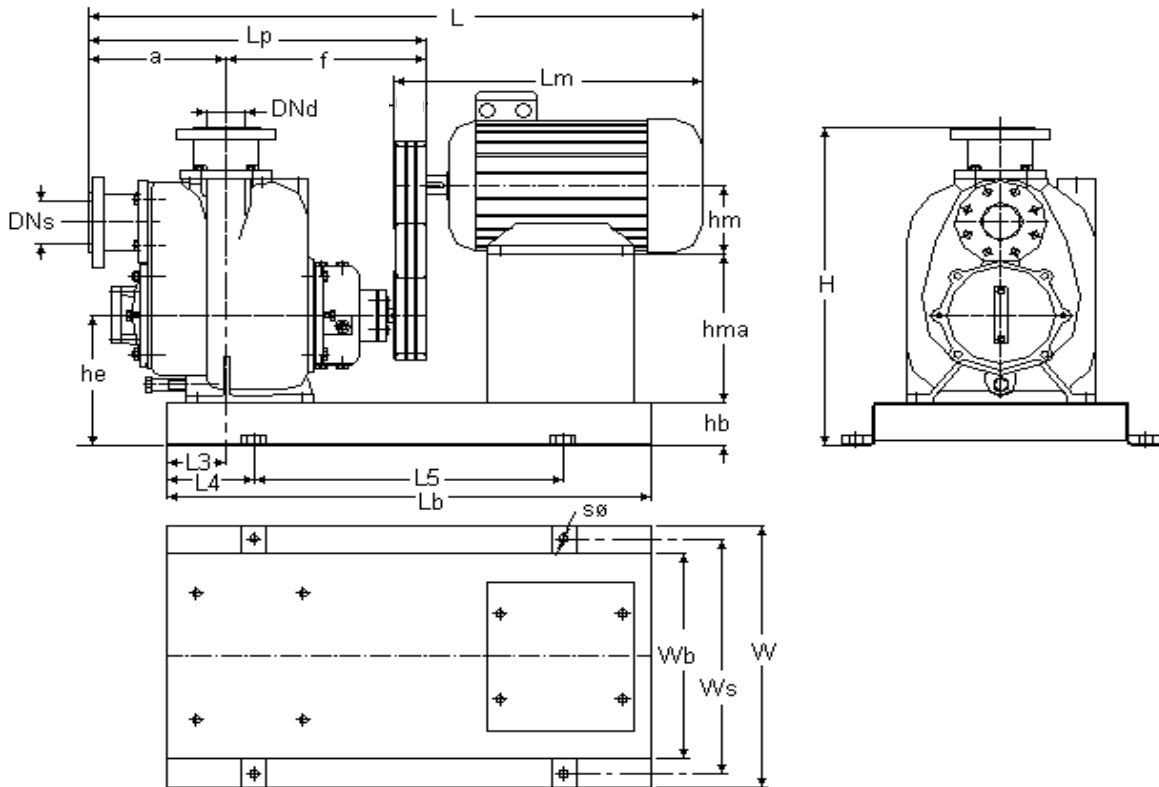

Pump	Motor			Pump					Foundation Dimensions											
RPM	kw	RPM	hm	Lm	a	f	Lp	L	L3	L4	L5	Lb	Wb	Ws	W	s	H	he	hb	hma
2150	18.5	1771	180	690	289	436	725	1374	107	200	800	1200	450	500	550	24	783	311	120	221
1950	15	1755	160	640	289	436	725	1325	107	200	800	1200	450	500	550	24	783	311	120	241
1750	*	*	*	*	*	*	*	*	*	*	*	*	*	*	*	*	*	*	*	*
1550	7.5	1745	132	505	289	436	725	1190	107	200	650	1050	450	500	550	24	783	311	120	266
1350	5.5	1155	132	505	289	436	725	1190	107	200	600	1050	450	500	550	24	783	311	120	259
1150	*	*	*	*	*	*	*	*	*	*	*	*	*	*	*	*	*	*	*	*
950	1.5	1125	100	375	289	436	725	1058	107	200	550	950	450	500	550	24	783	311	120	291

Pump RPM	Motor Side Belt Pulley Dia. (mm)	Pump Side Belt Pulley Dia. (mm)	Number of V-Belt	Length of V-Belts (mm)
2150	180	150	4	850
1950	180	160	4	875
1750	*	*	*	*
1550	140	160	3	800
1350	140	119	3	825
1150	*	*	*	*
950	140	160	1	650

UKM-S 3"x3" Self-Priming Centrifugal Pump
Main Dimensions (60 Hz Electric Motor with V-Belt Application)

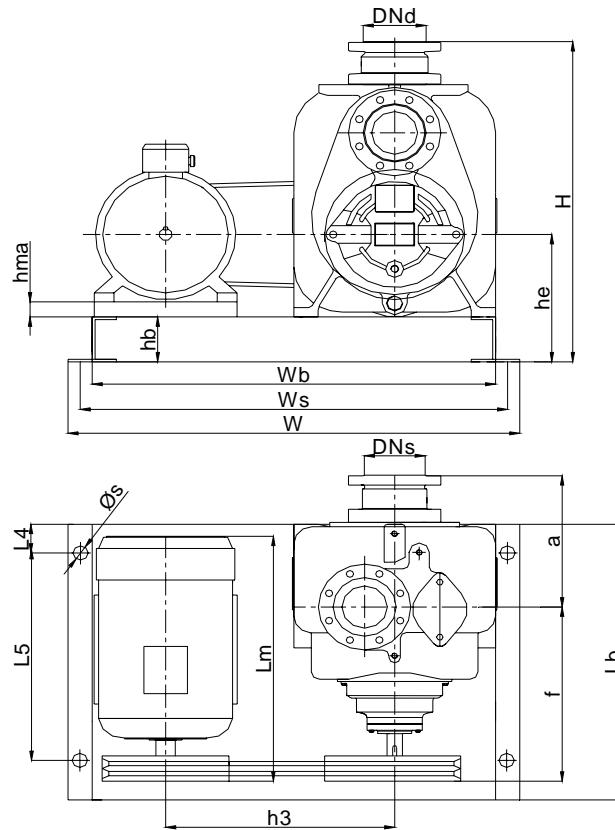

Pump RPM	Motor		Pump					Foundation Dimensions											
	kw	RPM	hm	Lm	a	f	Lp	L4	L5	Lb	Wb	Ws	W	s	H	he	hb	hma	h3
2150	18.5	1771	180	690	289	436	725	100	440	640	950	1000	1050	24	783	311	120	11	545
1950	15	1755	160	640	289	436	725	100	440	640	900	950	1000	24	783	311	120	31	525
1750	*	*	*	*	*	*	*	*	*	*	*	*	*	*	*	*	*	*	*
1550	7.5	1745	132	505	289	436	725	100	440	640	860	910	960	24	783	311	120	59	503
1350	5.5	1155	132	505	289	436	725	100	440	640	850	900	950	24	783	311	120	59	500
1150	4	*	*	*	*	*	*	*	*	*	*	*	*	*	*	*	*	*	*
950	1.5	1125	100	375	289	436	725	100	440	640	790	840	890	24	783	311	120	91	467

Pump RPM	Motor Side Belt Pulley Dia. (mm)	Pump Side Belt Pulley Dia. (mm)	Number of V-Belt	Length of V-Belts (mm)
2150	180	150	4	1525
1950	180	160	4	1500
1750	*	*	*	*
1550	140	160	3	1400
1350	140	119	3	1325
1150	*	*	*	*
950	140	160	1	1325

UKM-S 4"x4" Self-Priming Centrifugal Pump

Main Dimensions (60 Hz Electric Motor with V-Belt Application)

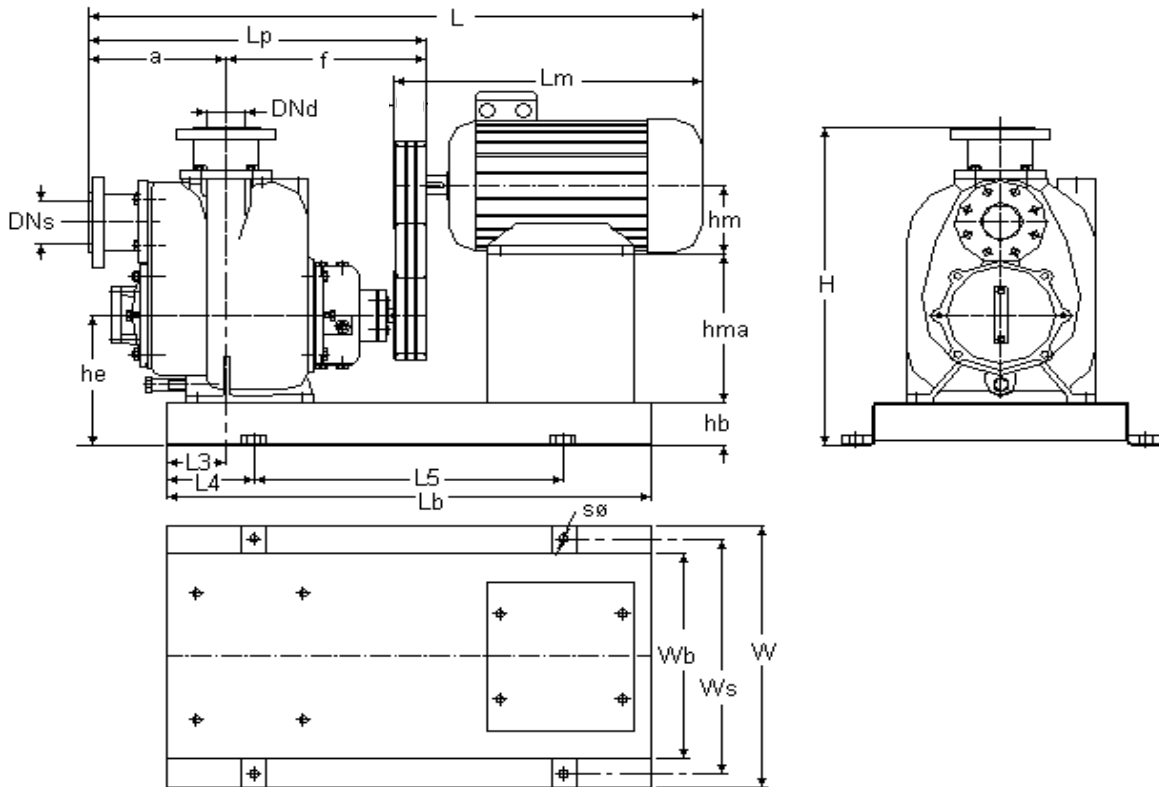

Pump RPM	Motor		Pump						Foundation Dimensions											
	kw	RPM	hm	Lm	a	f	Lp	L	L3	L4	L5	Lb	Wb	Ws	W	s	H	he	hb	hma
1950	22	1772	180	730	318	499	817	1507	100	200	850	1250	500	550	600	24	855	340	120	280
1750	*	*	*	*	*	*	*	*	*	*	*	*	*	*	*	*	*	*	*	*
1550	15	1755	160	640	318	499	817	1417	100	200	850	1250	500	550	600	24	855	340	120	280
1350	11	1755	160	600	318	499	817	1377	100	200	850	1250	500	550	600	24	855	340	120	280
1150	*	*	*	*	*	*	*	*	*	*	*	*	*	*	*	*	*	*	*	*
950	4	1160	132	505	318	499	817	1282	100	200	750	1050	500	550	600	24	855	340	120	298
750	2.2	1147	112	400	318	499	817	1177	100	200	750	1050	500	550	600	24	855	340	120	333

Pump RPM	Motor Side Belt Pulley Dia. (mm)	Pump Side Belt Pulley Dia. (mm)	Number of V-Belt	Length of V-Belts (mm)
1950	200	180	4	950
1750	*	*	*	*
1550	180	160	4	900
1350	160	200	3	925
1150	*	*	*	*
950	150	180	2	850
750	150	224	1	975

UKM-S 4"x4" Self-Priming Centrifugal Pump

Main Dimensions (60 Hz Electric Motor with V-Belt Application)

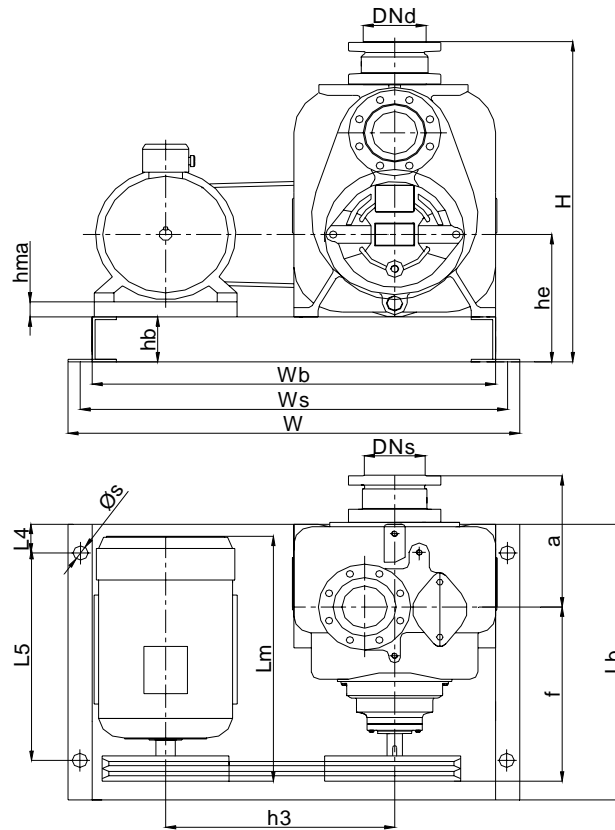

Pump RPM	Motor		Pump					Foundation Dimensions											
	kw	RPM	hm	Lm	a	f	Lp	L4	L5	Lb	Wb	Ws	W	s	H	he	hb	hma	h3
1950	22	1772	180	730	318	499	817	100	540	740	1010	1060	1110	24	855	340	120	40	579
1750	*	*	*	*	*	*	*	*	*	*	*	*	*	*	*	*	*	*	*
1550	15	1755	160	640	318	499	817	100	540	740	970	1020	1070	24	855	340	120	60	557
1350	11	1755	160	600	318	499	817	100	540	740	970	1020	1070	24	855	340	120	60	557
1150	*	*	*	*	*	*	*	*	*	*	*	*	*	*	*	*	*	*	*
950	4	1160	132	505	318	499	817	100	540	740	920	970	1020	24	855	340	120	88	531
750	2.2	1147	112	400	318	499	817	100	540	740	880	930	980	24	855	340	120	103	507

Pump RPM	Motor Side Belt Pulley Dia. (mm)	Pump Side Belt Pulley Dia. (mm)	Number of V-Belt	Length of V-Belts (mm)
1950	200	180	4	1675
1750	*	*	*	*
1550	180	160	4	1575
1350	160	200	3	1600
1150	*	*	*	*
950	150	180	2	1500
750	150	224	1	1525

UKM-S 6"x6" Self-Priming Centrifugal Pump

Main Dimensions (60 Hz Electric Motor with V-Belt Application)

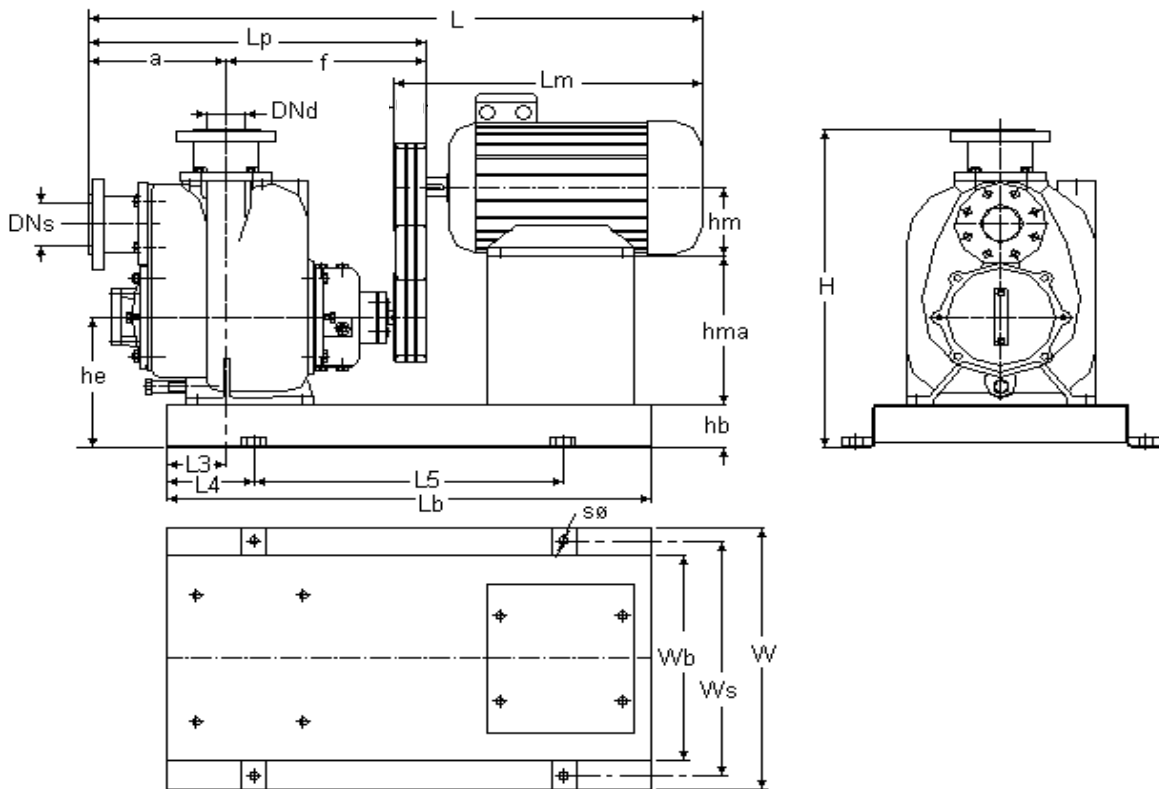

Pump RPM	Motor		Pump						Foundation Dimensions											
	kw	RPM	hm	Lm	a	f	Lp	L	L3	L4	L5	Lb	Wb	Ws	W	s	H	he	hb	hma
1550	30	1771	200	760	413	490	903	1622	236	200	1100	1500	600	650	700	24	1049	378	120	368
1450	30	1771	200	760	413	490	903	1622	236	200	1100	1500	600	650	700	24	1049	378	120	378
1350	22	1772	180	730	413	490	903	1593	236	200	1100	1500	600	650	700	24	1049	378	120	333
1250	18.5	1178	200	760	413	490	903	1622	236	200	1000	1400	600	650	700	24	1049	378	120	353
1150	*	*	*	*	*	*	*	*	*	*	*	*	*	*	*	*	*	*	*	*
1050	11	1170	160	640	413	490	903	1503	236	200	1000	1400	600	650	700	24	1049	378	120	343
950	7.5	1170	160	600	413	490	903	1463	236	200	950	1350	600	650	700	24	1049	378	120	348
850	5.5	1155	132	505	413	490	903	1368	236	200	900	1300	600	650	700	24	1049	378	120	361
750	4	1160	132	505	413	490	903	1368	236	200	900	1300	600	650	700	24	1049	378	120	346
650	3	1165	132	465	413	490	903	1328	236	200	900	1300	600	650	700	24	1049	378	120	366

Pump RPM	Motor Side Belt Pulley Dia. (mm)	Pump Side Belt Pulley Dia. (mm)	Number of V-Belt	Length of V-Belts (mm)
1550	250	280	4	1375
1450	250	300	4	1425
1350	180	236	4	1075
1250	250	236	4	1275
1150	*	*	*	*
1050	180	200	4	1000
950	180	224	3	1050
850	160	212	3	975
750	140	212	2	925
650	140	250	2	1025

UKM-S 6"x6" Self-Priming Centrifugal Pump

Main Dimensions (60 Hz Electric Motor with V-Belt Application)

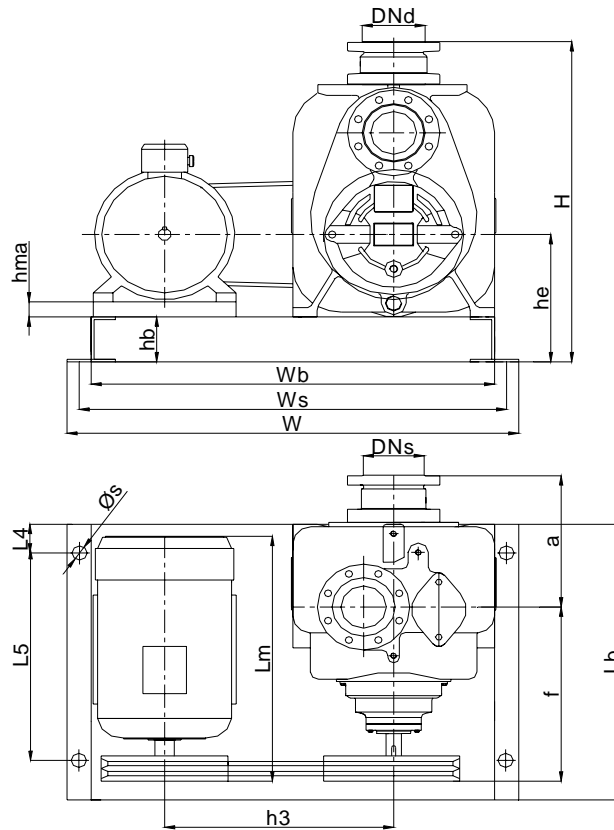

Pump RPM	Motor			Pump			Foundation Dimensions												
	kw	RPM	hm	Lm	a	f	Lp	L4	L5	Lb	Wb	Ws	W	s	H	he	hb	hma	h3
1550	30	1771	200	760	413	490	903	100	540	740	1220	1270	1320	24	1049	378	120	58	710
1450	30	1771	200	760	413	490	903	100	540	740	1220	1270	1320	24	1049	378	120	58	720
1350	22	1772	180	730	413	490	903	100	540	740	1100	1150	1200	24	1049	378	120	78	629
1250	18.5	1178	200	760	413	490	903	100	540	740	1135	1185	1235	24	1049	378	120	58	640
1150	*	*	*	*	*	*	*	*	*	*	*	*	*	*	*	*	*	*	*
1050	11	1170	160	640	413	490	903	200	340	740	1055	1105	1155	24	1049	378	120	98	605
950	7.5	1170	160	600	413	490	903	200	340	740	1050	1100	1155	24	1049	378	120	98	600
850	5.5	1155	132	505	413	490	903	200	340	740	1000	1050	1100	24	1049	378	120	126	575
750	4	1160	132	505	413	490	903	200	340	740	1000	1050	1100	24	1049	378	120	126	575
650	3	1165	132	465	413	490	903	200	340	740	1030	1080	1130	24	1049	378	120	126	595

Pump RPM	Motor Side Belt Pulley Dia. (mm)	Pump Side Belt Pulley Dia. (mm)	Number of V-Belt	Length of V-Belts (mm)
1550	250	280	4	2175
1450	250	300	4	2225
1350	180	236	4	1825
1250	250	236	4	1875
1150	*	*	*	*
1050	180	200	4	1725
950	180	224	3	1750
850	160	212	3	1650
750	140	212	2	1625
650	140	250	2	1725

UKM-S 8"x8" Self-Priming Centrifugal Pump

Main Dimensions (60 Hz Electric Motor with V-Belt Application)

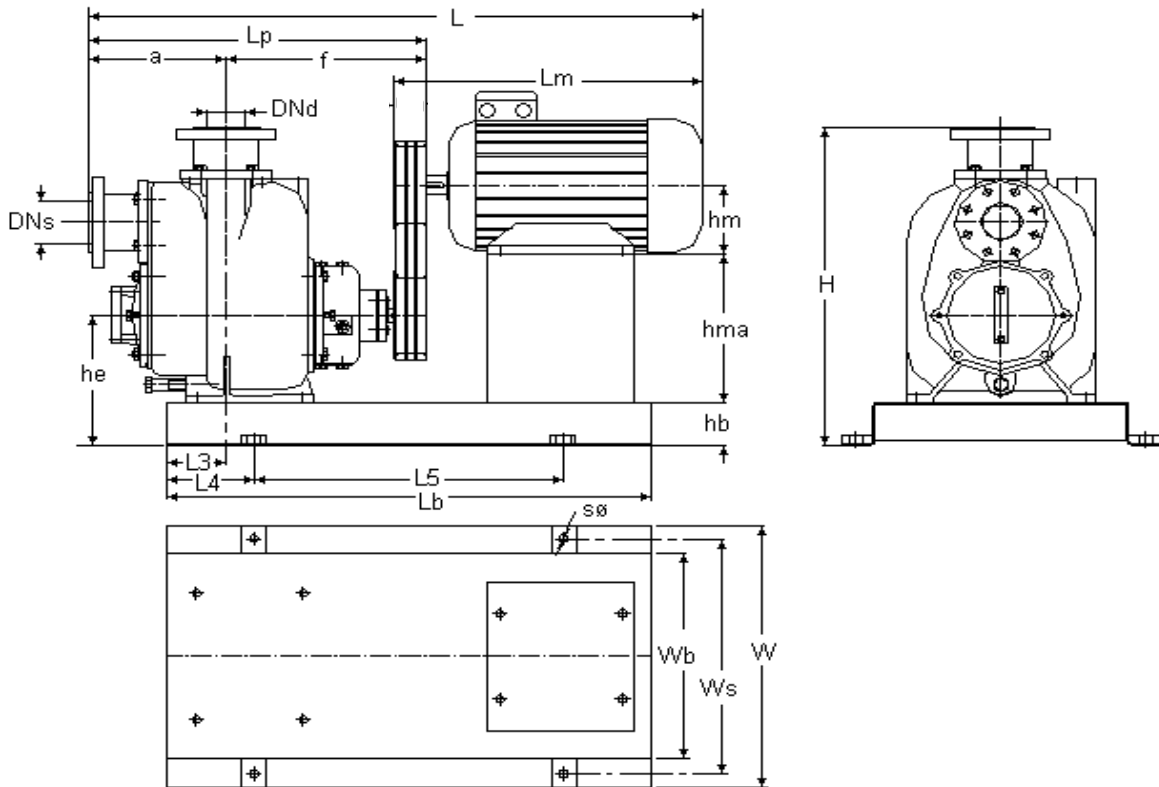

Pump RPM	Motor		Pump					Foundation Dimensions												
	kw	RPM	hm	Lm	a	f	Lp	L	L3	L4	L5	Lb	Wb	Ws	W	s	H	he	hb	hma
1350	55	1776	250	910	406	616	1022	1882	262	300	1400	1700	720	770	820	28	1208	496	160	486
1250	45	1185	280	985	406	616	1022	1957	262	300	1250	1850	720	770	820	28	1208	496	160	426
1150	*	*	*	*	*	*	*	*	*	*	*	*	*	*	*	*	*	*	*	*
1050	22	1177	200	760	406	616	1022	1732	262	300	1000	1600	720	770	820	28	1208	496	160	461
950	22	1177	200	760	406	616	1022	1732	262	300	1000	1600	720	770	820	28	1208	496	160	456
850	15	1177	180	730	406	616	1022	1701	262	300	1000	1600	720	770	820	28	1208	496	160	406
750	11	1170	160	640	406	616	1022	1612	262	300	900	1500	720	770	820	28	1208	496	160	451
650	7.5	1170	160	600	406	616	1022	1572	262	300	900	1500	720	770	820	28	1208	496	160	426

Pump RPM	Motor Side Belt Pulley Dia. (mm)	Pump Side Belt Pulley Dia. (mm)	Number of V-Belt	Length of V-Belts (mm)
1350	300	400	5	1825
1250	315	300	6	1625
1150	*	*	*	*
1050	250	280	4	1400
950	250	300	4	1425
850	180	250	4	1100
750	180	280	4	1200
650	160	280	3	1125

UKM-S 8"x8" Self-Priming Centrifugal Pump

Main Dimensions (60 Hz Electric Motor with V-Belt Application)

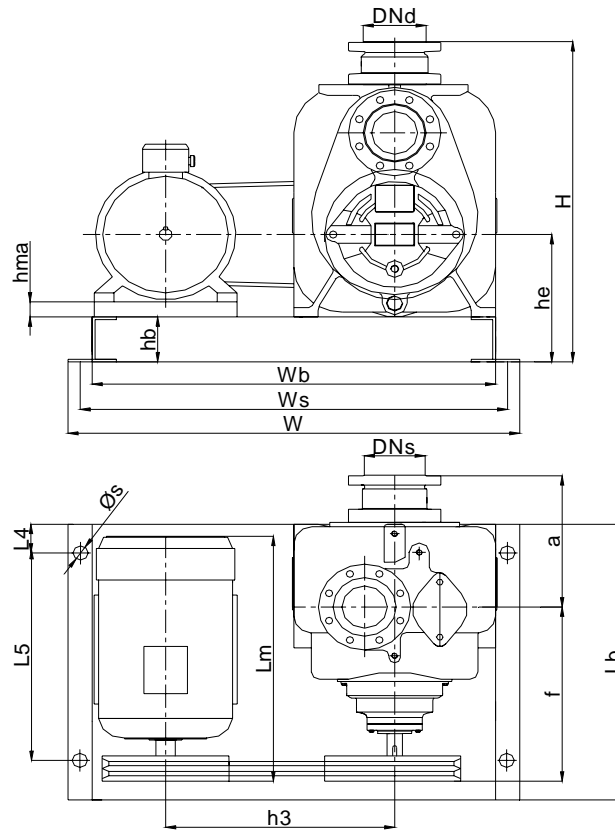

Pump RPM	Motor		Pump			Foundation Dimensions													
	kw	RPM	hm	Lm	a	f	Lp	L4	L5	Lb	Wb	Ws	W	s	H	he	hb	hma	h3
1350	55	1776	250	910	406	616	1022	200	550	950	1340	1390	1440	28	1208	496	160	96	740
1250	45	1185	280	985	406	616	1022	200	550	950	1420	1470	1520	28	1208	496	160	63	782
1150	*	*	*	*	*	*	*	*	*	*	*	*	*	*	*	*	*	*	*
1050	22	1177	200	760	406	616	1022	200	550	950	1270	1320	1370	28	1208	496	160	136	712
950	22	1177	200	760	406	616	1022	200	550	950	1270	1320	1370	28	1208	496	160	136	710
850	15	1177	180	730	406	616	1022	200	550	950	1230	1280	1330	28	1208	496	160	156	700
750	11	1170	160	640	406	616	1022	200	550	950	1190	1240	1290	28	1208	496	160	176	665
650	7.5	1170	160	600	406	616	1022	200	550	950	1190	1240	1290	28	1208	496	160	176	670

Pump RPM	Motor Side Belt Pulley Dia. (mm)	Pump Side Belt Pulley Dia. (mm)	Number of V-Belt	Length of V-Belts (mm)
1350	300	400	5	2300
1250	315	300	6	2450
1150	*	*	*	*
1050	250	280	4	2175
950	250	300	4	2200
850	180	250	4	2000
750	180	280	4	1975
650	160	280	3	1975

UKM-S 10"x10" Self-Priming Centrifugal Pump
Main Dimensions (60 Hz Electric Motor with V-Belt Application)

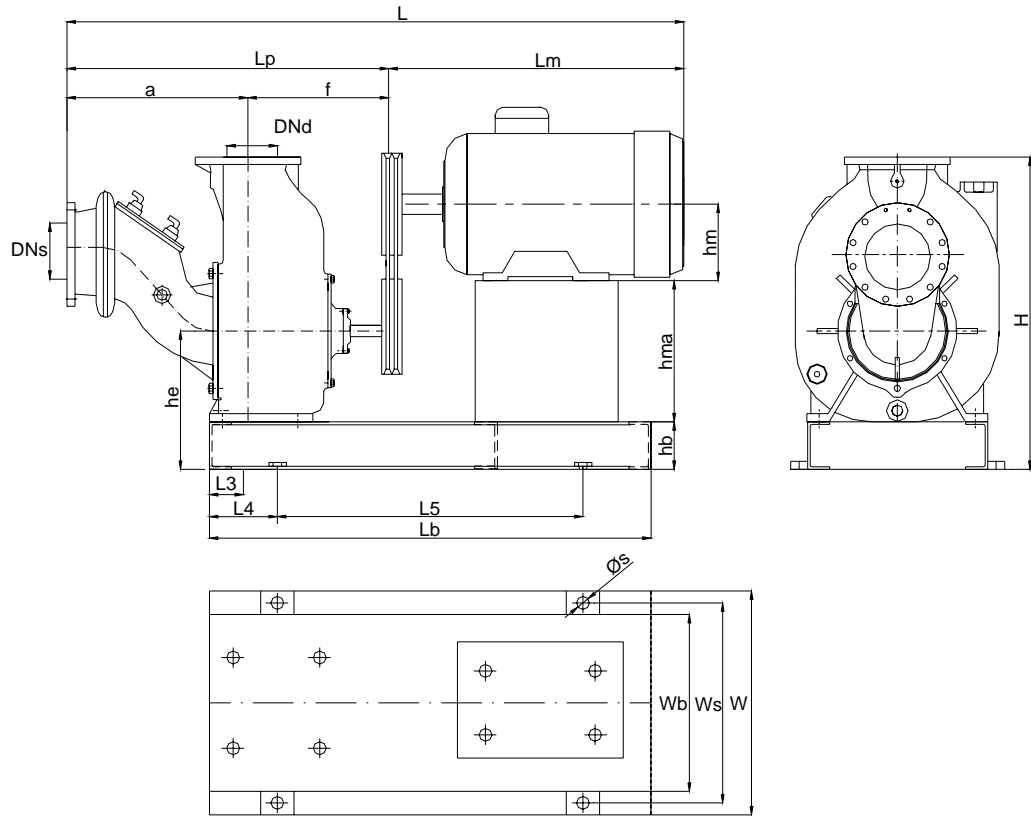

Pump RPM	Motor		Pump					Foundation Dimensions												
	kw	RPM	h _m	L _m	a	f	L _p	L	L ₃	L ₄	L ₅	L _b	W _b	W _s	W	s	H	h _e	h _b	h _{ma}
1450	75	1785	280	985	710	523	1233	2168	151	300	1000	1600	720	770	820	28	1199	516	160	476
1350	75	1785	280	985	710	523	1233	2168	151	300	1000	1600	720	770	820	28	1199	516	160	476
1250	55	1185	280	1035	710	523	1233	2218	151	300	1050	1650	720	770	820	28	1199	516	160	436
1150	*	*	*	*	*	*	*	*	*	*	*	*	*	*	*	*	*	*	*	*
1050	37	1178	250	910	710	523	1233	2093	151	300	1050	1650	720	770	820	28	1199	516	160	466
950	30	1183	225	835	710	523	1233	2018	151	300	950	1550	720	770	820	28	1199	516	160	496
850	18.5	1178	200	760	710	523	1233	1943	151	300	850	1450	720	770	820	28	1199	516	160	506
750	15	1177	180	730	710	523	1233	1913	151	300	850	1450	720	770	820	28	1199	516	160	451

Pump RPM	Motor Side Belt Pulley Dia. (mm)	Pump Side Belt Pulley Dia. (mm)	Number of V-Belt	Length of V-Belts (mm)
1450	315	400	6	1850
1350	300	400	6	1825
1250	315	300	6	1600
1150	*	*	*	*
1050	280	315	5	1575
950	280	355	4	1650
850	250	355	4	1575
750	180	280	4	1200

UKM-S 10"x10" Self-Priming Centrifugal Pump
Main Dimensions (60 Hz Electric Motor with V-Belt Application)

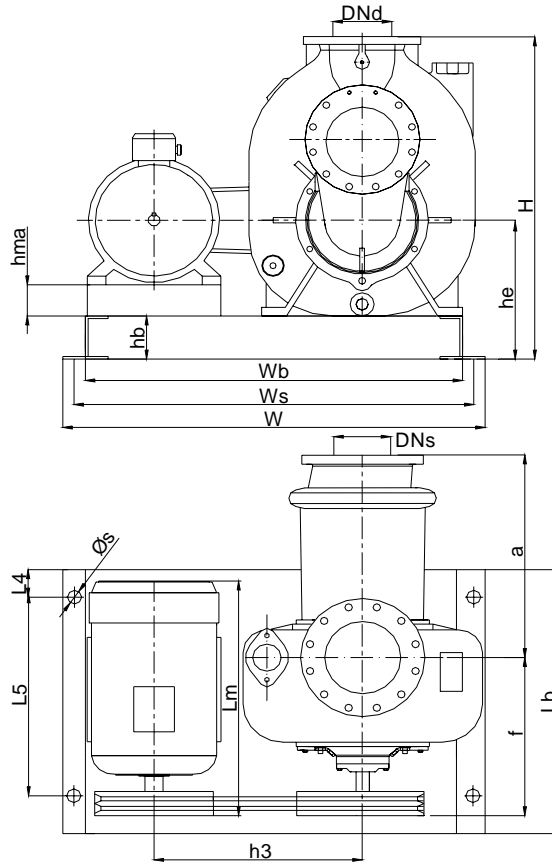

Pump RPM	Motor			Pump			Foundation Dimensions												
	kw	RPM	hm	Lm	a	f	Lp	L4	L5	Lb	Wb	Ws	W	s	H	he	hb	hma	h3
1450	75	1785	280	985	710	523	1233	200	390	790	1480	1530	1580	28	1199	516	160	76	840
1350	75	1785	280	985	710	523	1233	200	390	790	1480	1530	1580	28	1199	516	160	76	840
1250	55	1185	280	1035	710	523	1233	200	390	790	1470	1520	1570	28	1199	516	160	76	835
1150	*	*	*	*	*	*	*	*	*	*	*	*	*	*	*	*	*	*	*
1050	37	1178	250	910	710	523	1233	200	390	790	1410	1460	1510	28	1199	516	160	106	810
950	30	1183	225	835	710	523	1233	200	390	790	1350	1400	1450	28	1199	516	160	131	767
850	18.5	1178	200	760	710	523	1233	200	390	790	1300	1350	1400	28	1199	516	160	156	740
750	15	1177	180	730	710	523	1233	200	390	790	1260	1310	1360	28	1199	516	160	176	726

Pump RPM	Motor Side Belt Pulley Dia. (mm)	Pump Side Belt Pulley Dia. (mm)	Number of V-Belt	Length of V-Belts (mm)
1450	315	400	6	2725
1350	300	400	6	2700
1250	315	300	6	2550
1150	*	*	*	*
1050	280	315	5	2475
950	280	355	4	2450
850	250	355	4	2350
750	180	280	4	2100

UKM-S Self-Priming Centrifugal Pump

Diesel Engine Application



PUMP TYPE	PUMP SPEED	GEARBOX RATIO			
			LOMBARDINI	VM MOTORI S.p.A.	JOHN DEERE
UKM-S 10 X 10	1325	1.66	-	4105 TE	4039 T
UKM-S 10 X 10	1200	1.66	-	4105 TE	4039 T
UKM-S 10 X 10	1084	1.66	-	3105 T	4039 D
UKM-S 10 X 10	964	1.66	-	3105	3029 D
UKM-S 8 X 8	1325	1.66	-	3105 T	4039 D
UKM-S 8 X 8	1204	1.66	-	3105	4039 D
UKM-S 8 X 8	1084	1.66	2204 / T	2105	3029 D
UKM-S 8 X 8	964	1.66	-	2105	3029 D
UKM-S 8 X 8	850	1.66	-	2105	-
UKM-S 6 X 6	1550	-	-	3105T	4039D
UKM-S 6 X 6	1450	-	-	3105	3029D
UKM-S 4 X 4	1950	-	LDW 2204	2105	3029D
UKM-S 4 X 4	1850	-	LDW 2204	2105	3029D
UKM-S 4 X 4	1750	-	11LD 626/3	2105	-
UKM-S 4 X 4	1650	-	11LD 626/3	2105	-
UKM-S 3 X 3	2150	-	11LD 522/3	-	-
UKM-S 3 X 3	1950	-	11LD 522/3	-	-
UKM-S 3 X 3	1750	-	9 LD 626/2	-	-
UKM-S 3 X 3	1550	-	9 LD 626/2	-	-
UKM-S 2 X 2	2900	-	25LD 330/2	-	-
UKM-S 2 X 2	2600	-	25LD 330/2	-	-
UKM-S 2 X 2	2300	-	15LD 400	-	-
UKM-S 2 X 2	2000	-	15LD 350	-	-

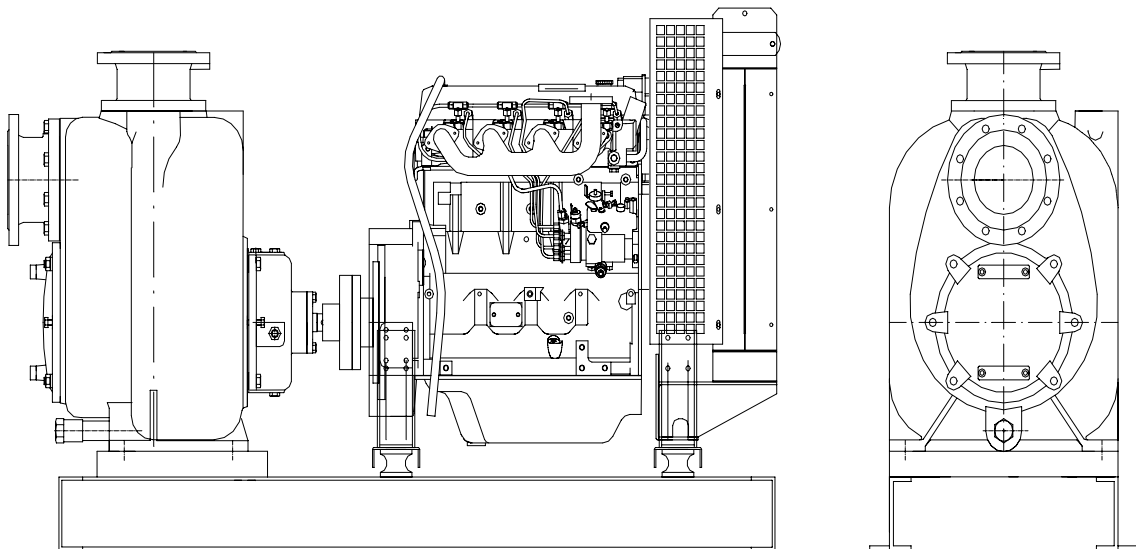

UKM-S Self-Priming Centrifugal Pump Exploded View

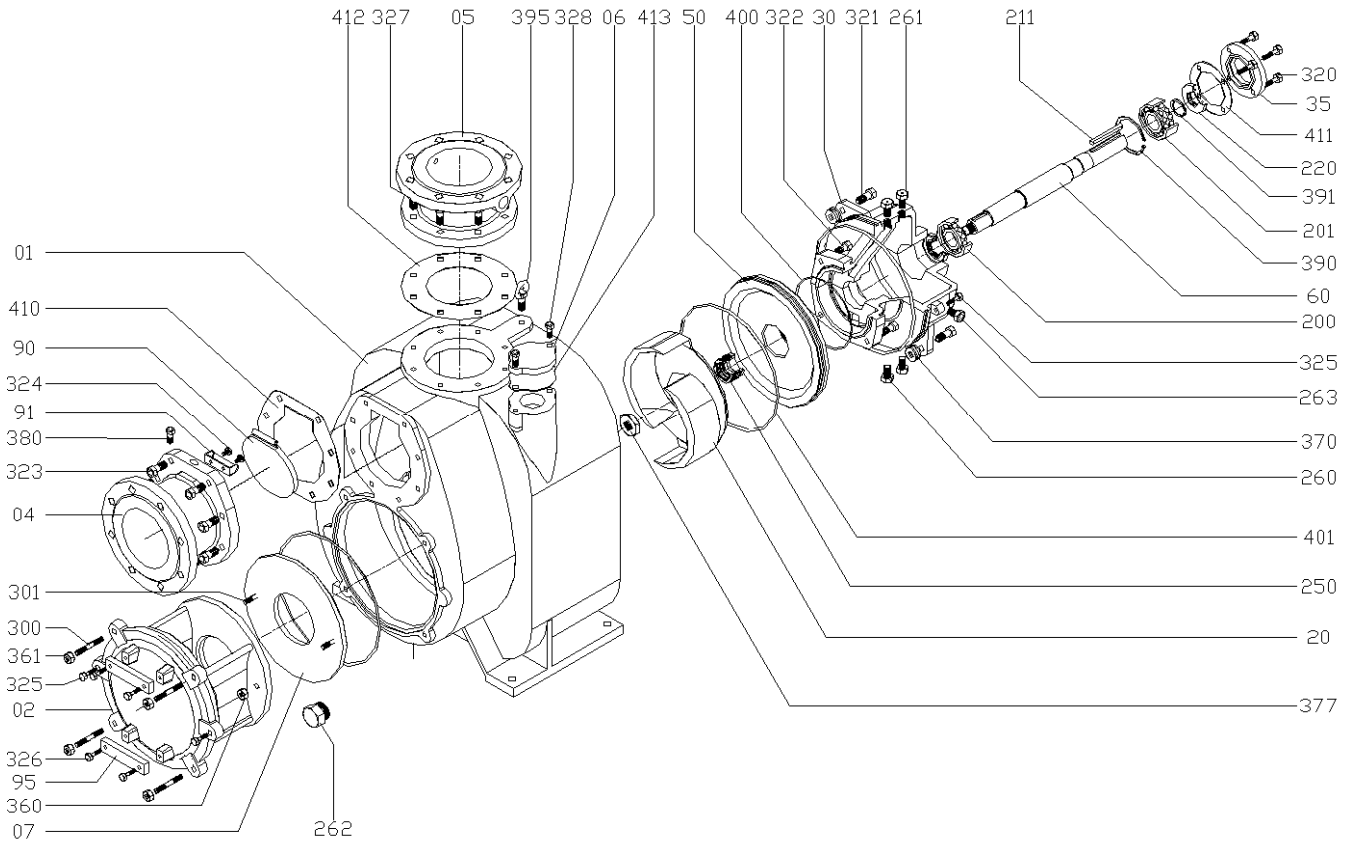

Part No	Part Name	Part No	Part Name	Part No	Part Name
01	Pump Casing	220	Oil Seal	360	Nut
02	Cover Plate	250	Mechanical Seal	361	Nut
04	Suction Flange	260	Pipe Plug	370	Washer
05	Discharge Flange	261	Pipe Plug	377	Washer, Impeller
06	Fill Cover	263	Pipe Plug	380	Cylindrical Pin
07	Wearing Plate	300	Stud	390	Ring
20	Impeller	301	Stud	391	Ring
30	Bearing Housing	320	Hex Bolt	395	Eye Bolt
35	Bearing Cover	321	Hex Bolt	400	O-Ring
60	Pump Shaft	322	Hex Bolt	401	O-Ring
90	Suction Flap Valve	323	Hex Bolt	410	Gasket
91	Suction Flap Valve Part	324	Hex Bolt	411	Gasket
95	Handling Plate	325	Hex Bolt	412	Gasket
200	Bearing	326	Hex Bolt	413	Gasket
201	Bearing	327	Hex Bolt		
211	Key	328	Hex Bolt		